



**DEPARTMENT
OF
CIVIL ENGINEERING
4TH SEMESTER**

**Lecture's Notes on
HIGHWAY ENGINEERING**

Prepared By

A.GUPTESWARA PATRA (PTGF In Civil)

UNIT 1
HIGHWAY DEVELOPMENT AND PLANNING

UNIT 1

HIGHWAY DEVELOPMENT AND PLANNING

Overview

Road transport is one of the most common modes of transport. Roads in the form of track ways, human pathways etc. were used even from the pre-historic times. Since then many experiments were going on to make the riding safe and comfort. Thus road construction became an inseparable part of many civilizations and empires. In this chapter we will see the different generations of road and their characteristic features. Also we will discuss about the highway planning in India.

History of highway engineering

The history of highway engineering gives us an idea about the roads of ancient times. Roads in Rome were constructed in a large scale and it radiated in many directions helping them in military operations. Thus they are considered to be pioneers in road construction. In this section we will see in detail about Ancient roads, Roman roads, British roads, French roads etc.

Ancient Roads

The earliest mode of transport was by foot. These human pathways would have been developed for specific purposes leading to camp sites, food, streams for drinking water etc. The next major mode of transport was the use of animals for transporting both men and materials. Since these loaded animals required more horizontal and vertical clearances than the walking man, track ways emerged. The invention of wheel in Mesopotamian civilization led to the development of animal drawn vehicles. Then it became necessary that the road surface should be capable of carrying greater loads. Thus roads with harder surfaces emerged. To provide adequate strength to carry the wheels, the new ways tended to follow the sunny drier side of a path. These have led to the development of foot-paths. After the invention of wheel, animal drawn vehicles were developed and the need for hard surface road emerged. Traces of such hard roads were obtained from various ancient civilization dated as old as 3500 BC. The earliest authentic record of road was found from Assyrian empire constructed about 1900 BC.

Roman roads

The earliest large scale road construction is attributed to Romans who constructed an extensive system of roads radiating in many directions from Rome. They were a remarkable achievement and provided travel times across

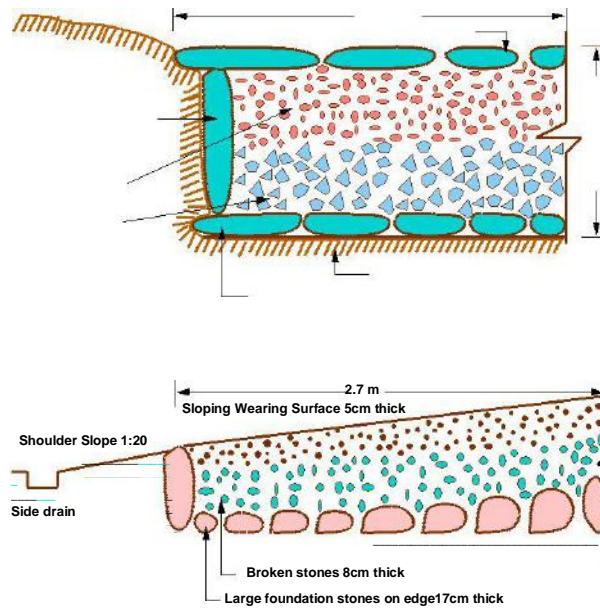

Figure 1.1: French roads

Europe, Asia Minor, and North Africa. Romans recognized that the fundamentals of good road construction were to provide good drainage, good material and good workmanship. Their roads were very durable, and some still exist. Roman roads were always constructed on a ram - formed sub grade strengthened where necessary with wooden piles. The roads were bordered on both sides by longitudinal drains. The next step was the construction of the aggregate. This was a raised formation up to a 1 meter high and 15 m wide and was constructed with materials excavated during the side drain construction. This was then topped with a sand leveling course. The aggregate contributed greatly to moisture control in the pavement. The pavement structure on the top of the aggregate varied greatly. In the case of heavy traffic, a surface course of large 250 mm thick hexagonal ag stones were provided. A typical cross section of roman road is given in Figure 1:1 The main features of the Roman roads are that they were built straight regardless of gradient and used heavy foundation stones at the bottom. They mixed lime and volcanic puzzolana to make mortar and they added gravel to this mortar to make concrete. Thus concrete was a major Roman road making innovation.

2.2.3 French roads

The next major development in the road construction occurred during the regime of Napoleon. The significant contributions were given by Tresaguet in 1764 and a typical cross section of this road is given in Figure 1:2. He developed a cheaper method of construction than the lavish and locally unsuccessful revival of Roman practice. The pavement used 200 mm pieces of quarried stone of a more compact form and shaped such that they had at least one at side which was placed on a compact formation. Smaller pieces of broken stones were then compacted into the spaces between larger stones to provide a level surface. Finally the running layer was made with a layer of 25 mm sized broken stone. All this structure was placed in a trench in order to keep the running surface

level with the surrounding country side. This created major drainage problems which were counteracted by making the surface as impervious as possible, cambering the surface and providing deep side ditches.

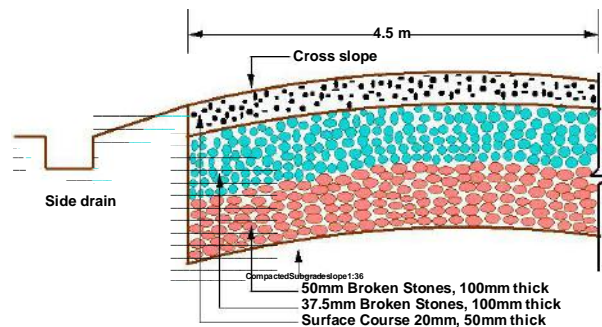

Figure 1:2: British roads

He gave much importance for drainage. He also enunciated the necessity for continuous organized maintenance, instead of intermittent repairs if the roads were to be kept usable all times. For this he divided the roads between villages into sections of such length that an entire road could be covered by maintenance men living nearby.

2.2.4 British roads

The British government also gave importance to road construction. The British engineer John Macadam introduced what can be considered as the best scientific road construction method. Stone size was an important element of Macadam recipe. By empirical observation of many roads, he came to realize that 250 mm layers of well compacted broken angular stone would provide the same strength and stiffness and a better running surface than an expensive pavement founded on large stone blocks. Thus he introduced an economical method of road construction.

The mechanical interlock between the individual stone pieces provided strength and stiffness to the course. But the inter particle friction abraded the sharp interlocking faces and partly destroy the 'effectiveness' of the course. This was overcome by introducing good quality interstitial material to produce a well-graded mix. Such mixes also proved less permeable and easier to compact. A typical cross section of British roads is given in Figure 1:2.

2.2.5 Modern roads

The modern roads by and large follow Macadam's construction method. Use of bituminous concrete and cement concrete are the most important developments. Various advanced and cost-effective construction technologies are used. Development of new equipments helps in the faster construction of roads. Many easily and locally available materials are tested in the laboratories and then

implemented on roads for making economical and durable pavements.

Scope of transportation system has developed very largely. Population of the country is increasing day by day. The life style of people began to change. The need for travel to various places at faster speeds also increased. This increasing demand led to the emergence of other modes of transportation like railways and travel by air. While the above development in public transport sector was taking place, the development in private transport was at a much faster rate mainly because of its advantages like accessibility, privacy, flexibility, convenience and comfort. This led to the increase in vehicular traffic especially in private transport network. Thus road space available was becoming insufficient to meet the growing demand of traffic and congestion started. In addition, chances for accidents also increased. This has led to the increased attention towards control of vehicles so that the transport infrastructure was optimally used. Various control measures like traffic signals, providing roundabouts and medians, limiting the speed of vehicle at specific zones etc. were implemented.

With the advancement of better roads and efficient control, more and more investments were made in the road sector especially after the World wars. These were large projects requiring large investment. For optimal utilization of funds, one should know the travel pattern and travel behavior. This has led to the emergence of transportation planning and demand management.

2.3 Highway planning in India

Excavations in the sites of Indus valley, Mohenjo-Daro and Harappa civilizations revealed the existence of planned roads in India as old as 2500-3500 BC. The Mauryan kings also built very good roads. Ancient books like Arthashastra written by Kautilya, a great administrator of the Mauryan times, contained rules for regulating track, depths of roads for various purposes, and punishments for obstructing traffic.

During the time of Mughal period, roads in India were greatly improved. Roads linking North-West and the Eastern areas through gangetic plains were built during this time.

After the fall of the Mughals and at the beginning of British rule, many existing roads were improved. The construction of Grand-Trunk road connecting North and South is a major contribution of the British. However, the focus was later shifted to railways, except for feeder roads to important stations.

2.3.1 Modern developments

The First World War period and that immediately following it found a rapid growth in motor transport. So need for better roads became a necessity. For that, the Government of India appointed a committee called Road development Committee with Mr.M.R. Jayakar as the chairman. This committee came to be known as Jayakar committee.

Jayakar Committee

In 1927 Jayakar committee for Indian road development was appointed. The major

recommendations and the resulting implementations were:

Committee found that the road development of the country has become beyond the capacity of local governments and suggested that Central government should take the proper charge considering it as a matter of national interest.

They gave more stress on long term planning programme, for a period of 20 years (hence called twenty year plan) that is to formulate plans and implement those plans within the next 20 years.

One of the recommendations was the holding of periodic road conferences to discuss about road construction and development. This paved the way for the establishment of a semi-official technical body called Indian Road Congress (IRC) in 1934

The committee suggested imposition of additional taxation on motor transport which includes duty on motor spirit, vehicle taxation, license fees for vehicles plying for hire. This led to the introduction of a development fund called Central road fund in 1929. This fund was intended for road development.

INTRODUCTION TO HIGHWAY ENGINEERING

A dedicated research organization should be constituted to carry out research and development work. This resulted in the formation of Central Road Research Institute (CRRRI) in 1950.

Nagpur road congress 1943

The Second World War saw a rapid growth in road traffic and this led to the deterioration in the condition of roads. To discuss about improving the condition of roads, the government convened a conference of chief engineers of provinces at Nagpur in 1943. The result of the conference is famous as the Nagpur plan.

A twenty year development programme for the period (1943-1963) was finalized. It was the first attempt to prepare a co-ordinate road development programme in a planned manner.

The roads were divided into five classes:

- National highways which would pass through states, and places having national importance for strategic, administrative and other purposes.
- State highways which would be the other main roads of a state.
- District roads which would take traffic from the main roads to the interior of the district . According to the importance, some are considered as major district roads and the remaining as other district roads.
- Village roads which would link the villages to the road system.

The committee planned to construct 2 lakh kms of road across the country within 20 years.

They recommended the construction of star and grid pattern of roads throughout the country.

One of the objectives was that the road length should be increased so as to give a road density of 16kms per 100 sq.km

Bombay road congress 1961

The length of roads envisaged under the Nagpur plan was achieved by the end of it, but the road system was deficient in many respects. The changed economic, industrial and agricultural conditions in the country warranted a review of the Nagpur plan. Accordingly a 20-year plan was drafted by the Roads wing of Government of India, which is popularly known as the Bombay plan. The highlights of the plan were:

It was the second 20 year road plan (1961-1981)

The total road length targeted to construct was about 10 lakhs.

Rural roads were given specific attention. Scientific methods of construction were proposed for the rural roads. The necessary technical advice to the Panchayaths should be given by State PWD's.

They suggested that the length of the road should be increased so as to give a road density of 32kms/100 sq.km

The construction of 1600 km of expressways was also then included in the plan.

Luck now road congress 1984

This plan has been prepared keeping in view the growth pattern envisaged in various elds by the turn of the century. Some of the salient features of this plan are as given below:

This was the third 20 year road plan (1981-2001). It is also called Lucknow road plan.

It aimed at constructing a road length of 12 lakh kilometers by the year 1981 resulting in a road density of 82kms/100 sq.km

The plan has set the target length of NH to be completed by the end of seventh, eighth and ninth five year plan periods.

It aims at improving the transportation facilities in villages, towns etc. such that no part of country is farther than 50 km from NH.

One of the goals contained in the plan was that expressways should be constructed on major traffic corridors to provide speedy travel.

Energy conservation, environmental quality of roads and road safety measures were also given due importance in this plan.

UNIT 2
HIGHWAY GEOMETRIC DESIGN

UNIT 2

HIGHWAY GEOMETRIC DESIGN

Overview

The features of the cross-section of the pavement influence the life of the pavement as well as the riding comfort and safety. Of these, pavement surface characteristics affect both of these. Camber, kerbs, and geometry of various cross-sectional elements are important aspects to be considered in this regard. They are explained briefly in this chapter.

Pavement surface characteristics

For safe and comfortable driving four aspects of the pavement surface are important; the friction between the wheels and the pavement surface, smoothness of the road surface, the light reflection characteristics of the top of pavement surface, and drainage to water.

Friction

Friction between the wheel and the pavement surface is a crucial factor in the design of horizontal curves and thus the safe operating speed. Further, it also affects the acceleration and deceleration ability of vehicles. Lack of adequate friction can cause skidding or slipping of vehicles.

Skidding happens when the path traveled along the road surface is more than the circumferential movement of the wheels due to friction

Slip occurs when the wheel revolves more than the corresponding longitudinal movement along the road.

Various factors that affect friction are:

Type of the pavement (like bituminous, concrete, gravel), Condition of the pavement (dry or wet, hot or cold, etc), Condition of the tire (new or old), and Speed and load of the vehicle.

The frictional force that develops between the wheel and the pavement is the load acting multiplied by a factor called the coefficient of friction and denoted as f . The choice of the value of f is a very complicated issue since it depends on many variables. IRC suggests the coefficient of longitudinal friction as 0.35-0.4 depending on

the speed and coefficient of lateral friction as 0.15. The former is useful in sight distance calculation and the latter in horizontal curve design.

Unevenness

It is always desirable to have an even surface, but it is seldom possible to have such a one. Even if a road is constructed with high quality pavers, it is possible to develop unevenness due to pavement failures. Unevenness affect the vehicle operating cost, speed, riding comfort, safety, fuel consumption and wear and tear of tyres.

Unevenness index is a measure of unevenness which is the cumulative measure of vertical undulations of the pavement surface recorded per unit horizontal length of the road. An unevenness index value less than 1500 mm/km is considered as good, a value less than 2500 mm.km is satisfactory up to speed of 100 kmph and values greater than 3200 mm/km is considered as uncomfortable even for 55 kmph.

Light reflection

White roads have good visibility at night, but caused glare during day time. Black roads has no glare during day, but has poor visibility at night Concrete roads has better visibility and less glare

It is necessary that the road surface should be visible at night and reflection of light is the factor that answers it.

Drainage

The pavement surface should be absolutely impermeable to prevent seepage of water into the pavement layers. Further, both the geometry and texture of pavement surface should help in draining out the water from the surface in less time.

Camber

Camber or cant is the cross slope provided to raise middle of the road surface in the transverse direction to drain o rain water from road surface. The objectives of providing camber are:

Surface protection especially for gravel and bituminous roads Sub-grade protection by proper drainage quick drying of pavement which in turn increases safety

Too steep slope is undesirable for it will erode the surface. Camber is measured in 1 in n or n% (Eg. 1 in 50 or 2%) and the value depends on the type of pavement surface. The values suggested by IRC for various categories of pavement are given in Table 12:1. The common types of camber are parabolic, straight,

or combination of them (Figure 12:1)

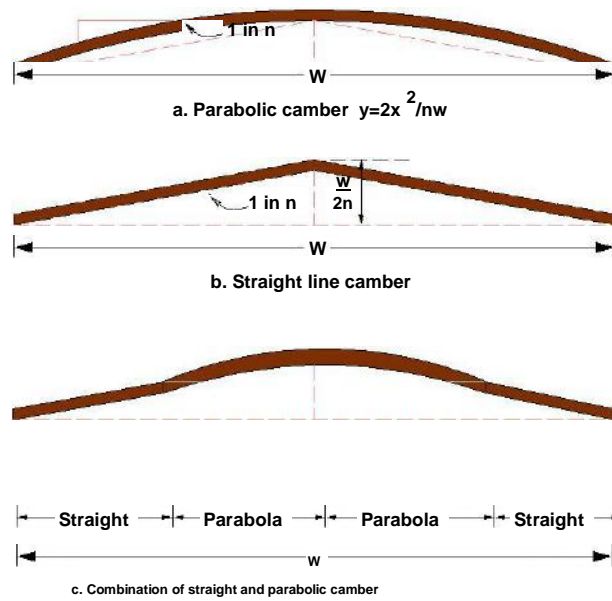

Figure 2:1: Different types of camber

Surface type	Heavy rain	Light rain
Concrete/Bituminous	2 %	1.7 %
Gravel/WBM	3 %	2.5 %
Earthen	4 %	3.0 %

Table 2:1: IRC Values for camber

Width of carriage way

Width of the carriage way or the width of the pavement depends on the width of the traffic lane and number of lanes. Width of a traffic lane depends on the width of the vehicle and the clearance. Side clearance improves operating speed and safety. The maximum permissible width of a vehicle is 2.44 and the desirable side clearance for single lane traffic is 0.68 m. This require minimum of lane width of 3.75 m for a single lane road (Table: 2.1a). However, the side clearance required is about 0.53 m, on either side or 1.06 m in the center. Therefore, a two lane road require minimum of 3.5 meter for each lane (Figure 12:2b). The desirable carriage way width recommended by IRC is given in Table 12:2

Table 2:1a: IRC Specification for carriage way width

Single lane	3.75
Two lane, no kerbs	7.0
Two lane, raised kerbs	7.5
Intermediate carriage	5.5
Multi-lane	3.5

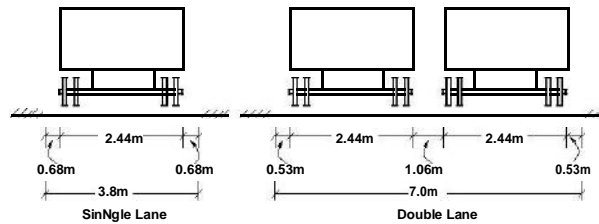

Figure 12:2: Lane width for single and two lane roads

Kerbs

Kerbs indicate the boundary between the carriage way and the shoulder or islands or footpaths.

Different types of kerbs are (Figure 12:3):

Low or mountable kerbs : This type of kerbs are provided such that they encourage the traffic to remain in the through traffic lanes and also allow the driver to enter the shoulder area with little difficulty. The height of this kerb is about 10 cm above the pavement edge with a slope which allows the vehicle to climb easily. This is usually provided at medians and channelization schemes and also helps in longitudinal drainage.

Semi-barrier type kerbs : When the pedestrian traffic is high, these kerbs are provided. Their height is 15 cm above the pavement edge. This type of kerb prevents encroachment of parking vehicles, but at acute emergency it is possible to drive over this kerb with some difficulty.

Barrier type kerbs: They are designed to discourage vehicles from leaving the pavement. They are provided when there is considerable amount of pedestrian traffic. They are placed at a height of 20 cm above the pavement edge with a steep batter.

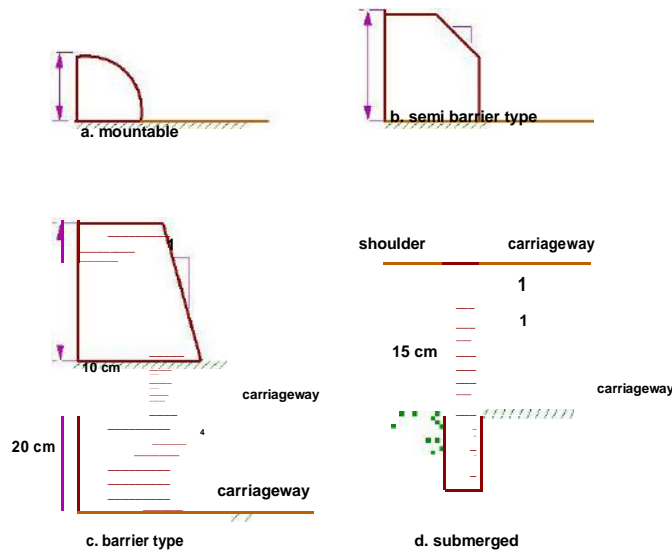

Figure 12:3: Different types of kerbs

Submerged kerbs : They are used in rural roads. The kerbs are provided at pavement edges between the pavement edge and shoulders. They provide lateral confinement and stability to the pavement.

Road margins

The portion of the road beyond the carriageway and on the roadway can be generally called road margin. Various elements that form the road margins are given below.

Shoulders

Shoulders are provided along the road edge and are intended for accommodation of stopped vehicles, serve as an emergency lane for vehicles and provide lateral support for base and surface courses. The shoulder should be strong enough to bear the weight of a fully loaded truck even in wet conditions. The shoulder width should be adequate for giving working space around a stopped vehicle. It is desirable to have a width of 4.6 m for the shoulders. A minimum width of 2.5 m is recommended for 2-lane rural highways in India.

Parking lanes

Parking lanes are provided in urban lanes for side parking. Parallel parking is preferred because it is safe for the vehicles moving on the road. The parking lane should have a minimum of 3.0 m width in the case of parallel parking.

Bus-bays

Bus bays are provided by recessing the kerbs for bus stops. They are provided so that they do not obstruct the movement of vehicles in the carriage way. They should be at least 75 meters away from the intersection so that the traffic near the intersections is not affected by the bus-bay.

Service roads

Service roads or frontage roads give access to access controlled highways like freeways and expressways. They run parallel to the highway and will be usually isolated by a separator and access to the highway will be provided only at selected points. These roads are provided to avoid congestion in the expressways and also the speed of the traffic in those lanes is not reduced.

Cycle track

Cycle tracks are provided in urban areas when the volume of cycle traffic is high. Minimum width of 2 meter is required, which may be increased by 1 meter for every additional track.

Footpath

Footpaths are exclusive right of way to pedestrians, especially in urban areas. They are provided for the safety of the pedestrians when both the pedestrian traffic and vehicular traffic is high. Minimum width is 1.5 meter and may be increased based on the traffic. The footpath should be either as smooth as the pavement or smoother than that to induce the pedestrian to use the footpath.

Guard rails

They are provided at the edge of the shoulder usually when the road is on an embankment. They serve to prevent the vehicles from running over the embankment, especially when the height exceeds 3 m. various designs of guard rails are there. Guard stones painted in alternate black and white are usually used. They also give better visibility of curves at night under headlights of vehicles.

Width of formation

Width of formation or roadway width is the sum of the widths of pavements or carriage way including separators and shoulders. This does not include the extra land in formation/cutting. The values suggested by IRC are given in Table 12:3.

Table 12:3: Width of formation for various classed of roads

Road classification	Roadway width in m	
	Plain and rolling terrain	Mountainous and steep terrain
NH/SH	12	6.25-8.8
MDR	9	4.75
ODR	7.5-9.0	4.75
VR	7.5	4.0

Right of way

Right of way (ROW) or land width is the width of land acquired for the road, along its alignment. It should be adequate to accommodate all the cross-sectional elements of the highway and may reasonably provide for future development. To prevent ribbon development along highways, control lines and building lines may be provided. Control line is a line which represents the nearest limits of future uncontrolled building activity in relation to a road. Building line represents a line on either side of the road; between which and the road no building activity is permitted at all. The right of way width is governed by:

Width of formation: It depends on the category of the highway and width of roadway and road margins. Height of embankment or depth of cutting: It is governed by the topography and the vertical alignment. Side slopes of embankment or cutting: It depends on the height of the slope, soil type etc.

Drainage system and their size which depends on rainfall, topography etc.

Sight distance considerations: On curves etc. there is restriction to the visibility on the inner side of the curve due to the presence of some obstructions like building structures etc.

Reserve land for future widening: Some land has to be acquired in advance anticipating future developments like widening of the road.

Table 12:4: Normal right of way for open areas

Road classification	Roadway width in m	
	Plain and rolling terrain	Mountainous and steep terrain
Open areas		
NH/SH	45	24
MDR	25	18
ODR	15	15
VR	12	9
Built-up areas		
NH/SH	30	20
MDR	20	15
ODR	15	12
VR	10	9

The importance of reserved land is emphasized by the following. Extra width of land is available for the construction of roadside facilities. Land acquisition is not possible later, because the land may be occupied for various other purposes (buildings, business etc.) The normal ROW requirements for built up and open areas as specified by IRC is given in Table 12:4

Sight distance

Overview

The safe and efficient operation of vehicles on the road depends very much on the visibility of the road ahead of the driver. Thus the geometric design of the road should be done such that any obstruction on the road length could be visible to the driver from some distance ahead. This distance is said to be the sight distance.

Types of sight distance

Sight distance available from a point is the actual distance along the road surface, over which a driver from a specified height above the carriage way has visibility of stationary or moving objects.

Three sight distance situations are considered for design:

Stopping sight distance (SSD) or the absolute minimum sight distance

Intermediate sight distance (ISD) is defined as twice SSD

Overtaking sight distance (OSD) for safe overtaking operation

Head light sight distance is the distance visible to a driver during night driving under the illumination of head lights

Safe sight distance to enter into an intersection.

The most important consideration in all these is that at all times the driver traveling at the design speed of the highway must have sufficient carriageway distance within his line of vision to allow him to stop his vehicle before colliding with a slowly moving or stationary object appearing suddenly in his own traffic lane.

The computation of sight distance depends on:

Reaction time of the driver

Reaction time of a driver is the time taken from the instant the object is visible to the driver to the instant when the brakes are applied. The total reaction time may be split up into four components based on PIEV theory. In practice, all these times are usually combined into a total perception-reaction time suitable for design purposes as well as for easy measurement. Many of the studies show that drivers require about 1.5 to 2 secs under normal conditions. However, taking into consideration the variability of driver characteristics, a higher value is normally used in design. For example, IRC suggests a reaction time of 2.5 secs. Speed of the vehicle

The speed of the vehicle very much affects the sight distance. Higher the speed, more time will be required to stop the vehicle. Hence it is evident that, as the speed increases, sight distance also increases.

Efficiency of brakes

The efficiency of the brakes depends upon the age of the vehicle, vehicle characteristics etc. If the brake efficiency is 100%, the vehicle will stop the moment the brakes are applied. But practically, it is not possible to achieve 100% brake efficiency. Therefore the sight distance required will be more when the efficiency of brakes are less. Also for safe geometric design, we assume that the vehicles have only 50% brake efficiency.

Frictional resistance between the tyre and the road

The frictional resistance between the tyre and road plays an important role to bring the vehicle to stop. When the frictional resistance is more, the vehicles stop immediately. Thus sight required will be less. No separate provision for brake efficiency is provided while computing the sight distance. This is taken into account along with the factor of longitudinal friction. IRC has specified the value of longitudinal friction in between 0.35 to 0.4.

Gradient of the road.

Gradient of the road also affects the sight distance. While climbing up a gradient, the vehicle can stop immediately. Therefore sight distance required is less. While descending a gradient, gravity also comes into action and more time will be required to stop the vehicle. Sight distance required will be more in this case.

Stopping sight distance

Stopping sight distance (SSD) is the minimum sight distance available on a highway at any spot having sufficient length to enable the driver to stop a vehicle traveling at design speed, safely without collision with any other obstruction.

There is a term called safe stopping distance and is one of the important measures in traffic engineering. It is the distance a vehicle travels from the point at which a situation is first perceived to the time the deceleration is complete. Drivers must have adequate time if they are to suddenly respond to a situation. Thus in highway design, sight distance at least equal to the safe stopping distance should be provided. The stopping sight distance is the sum of lag distance and the braking distance. Lag distance is the distance the vehicle traveled during the reaction time t and is given by vt , where v is the velocity in m/sec . Braking distance is the distance traveled by the vehicle during braking operation. For a level road this is obtained by equating the work done in stopping the vehicle and the kinetic energy of the vehicle. If F is the maximum frictional force developed and the braking distance is l , then work done against friction in stopping the vehicle is $F l = f W l$ where W is the total weight of the vehicle. The kinetic energy at the design speed is

$$\frac{1}{2}mv^2 = \frac{1}{2} \frac{Wv^2}{g}$$
$$f W l = \frac{Wv^2}{2g}$$

Therefore, the SSD = lag distance + braking distance and given by:

$$SSD = vt + \frac{v^2}{2gf} \quad (13.1)$$

Where v is the design speed in m/sec , t is the reaction time in sec, g is the acceleration due to gravity and f is the coefficient of friction. The coefficient of friction f is given below for various design speed. When there is an

Table 13:1: Coefficient of longitudinal friction

Speed, kmph	<30	40	50	60	>80
f	0.40	0.38	0.37	0.36	0.35

Ascending gradient of say +n%, the component of gravity adds to braking action and hence braking distance is decreased. The component of gravity acting parallel to the surface which adds to the the braking force is equal to $W \sin N$ $W \tan N = W n=100$. Equating kinetic energy and work done:

$$f W + \frac{W n}{100} l = \frac{W v^2}{2g}$$

$$l = \frac{v^2}{\frac{n}{2g f + 100}}$$

Similarly the braking distance can be derived for a descending gradient. Therefore the general equation is given by Equation 13.2.

$$SSD = vt + \frac{v^2}{2g(f \pm 0.01n)} \tag{13.2}$$

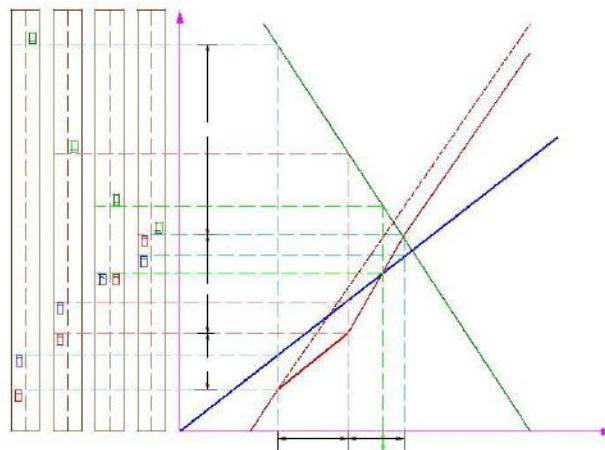

Figure 13:1: Time-space diagram: Illustration of overtaking sight distance

Overtaking sight distance

The overtaking sight distance is the minimum distance open to the vision of the driver of a vehicle intending to overtake the slow vehicle ahead safely against the traffic in the opposite direction. The overtaking sight distance or passing sight distance is measured along the center line of the road over which a driver with his eye level 1.2 m above the road surface can see the top of an object 1.2 m above the road surface.

The factors that affect the OSD are:

Velocities of the overtaking vehicle, overtaken vehicle and that of the vehicle coming in the opposite direction.

Spacing between vehicles, which in-turn depends on the speed

Skill and reaction time of the driver

Rate of acceleration of overtaking vehicle

Gradient of the road

The dynamics of the overtaking operation is given in the figure which is a time-space diagram. The x-axis denotes the time and y-axis shows the distance traveled by the vehicles. The trajectory of the slow moving vehicle (B) is shown as a straight line which indicates that it is traveling at a constant speed. A fast moving vehicle (A) is traveling behind the vehicle B. The trajectory of the vehicle is shown initially with a steeper slope. The dotted line indicates the path of the vehicle A if B was absent. The vehicle A slows down to follow the vehicle B as shown in the figure with same slope from t_0 to t_1 . Then it overtakes the vehicle B and occupies the left lane at time t_3 . The time duration $T = t_3 - t_1$ is the actual duration of the overtaking operation. The snapshots of the road at time t_0 ; t_1 , and t_3 are shown on the left side of the figure. From the Figure 13:1, the overtaking sight distance consists of three parts.

d_1 is the distance traveled by overtaking vehicle A during the reaction time $t = t_1 - t_0$

d_2 is the distance traveled by the vehicle during the actual overtaking operation $T = t_3 - t_1$

d_3 is the distance traveled by on-coming vehicle C during the overtaking operation (T).

Therefore:

$$\text{OSD} = d_1 + d_2 + d_3 \quad (13.3)$$

It is assumed that the vehicle A is forced to reduce its speed to v_b , the speed of the slow moving vehicle B and travels behind it during the reaction time t of the driver. So d_1 is given by:

$$d_1 = v_b t \quad (13.4)$$

Then the vehicle A starts to accelerate, shifts the lane, overtake and shift back to the original lane. The vehicle A maintains the spacing s before and after overtaking. The spacing s in m is given by:

$$s = 0.7v_b + 6 \quad (13.5)$$

Let T be the duration of actual overtaking. The distance traveled by B during the overtaking operation is $2s + v_b T$. Also, during this time, vehicle A accelerated from initial velocity v_b and overtaking is completed while reaching velocity v . Hence the distance traveled is given by:

$$\begin{aligned}
 d_2 &= v_b T + \frac{1}{2} a T^2 \\
 2s + v_b T &= v_b T + \frac{1}{2} a T^2 \\
 2s &= \frac{1}{2} a T^2 \\
 T &= r \frac{4s}{a} \\
 d^2 &= 2s + v_b \frac{r \frac{4s}{a}}{a} \quad (13.6)
 \end{aligned}$$

The distance traveled by the vehicle C moving at design speed v m/sec during overtaking operation is given by:

$$d_3 = vT \quad (13.7)$$

The overtaking sight distance is (Figure 13:1)

$$OSD = v_b t + 2s + v_b \frac{r \frac{4s}{a}}{a} + vT \quad (13.8)$$

Where v_b is the velocity of the slow moving vehicle in m/sec², t the reaction time of the driver in sec, s is the spacing between the two vehicle in m given by equation 13.5 and a is the overtaking vehicles acceleration in m/sec². In case the speed of the overtaken vehicle is not given, it can be assumed that it moves 16 kmph slower the the design speed.

The acceleration values of the fast vehicle depends on its speed and given in Table 13:2. Note that:

Table 13:2: Maximum overtaking acceleration at different speeds

Speed (kmph)	Maximum overtaking acceleration (m/sec ²)
25	1.41
30	1.30
40	1.24
50	1.11
65	0.92
80	0.72
100	0.53

On divided highways, d_3 need not be considered

On divided highways with four or more lanes, IRC suggests that it is not necessary to provide the OSD, but only SSD is sufficient.

Overtaking zones

Overtaking zones are provided when OSD cannot be provided throughout the length of the highway. These are zones dedicated for overtaking operation, marked with wide roads. The desirable length of overtaking zones is 5 time OSD and the minimum is three times OSD (Figure 13:2).

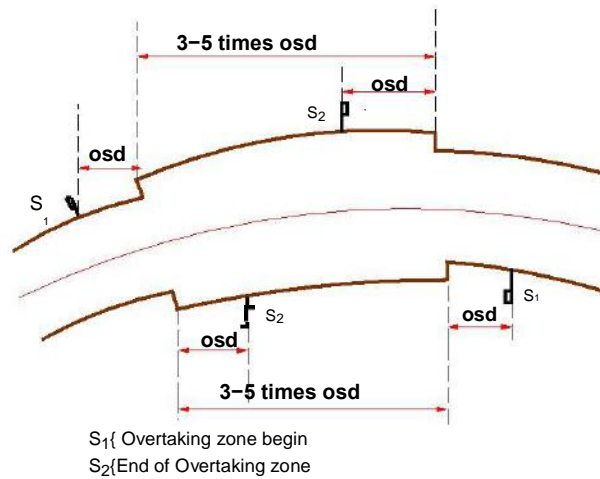

Figure 13:2: Overtaking zones

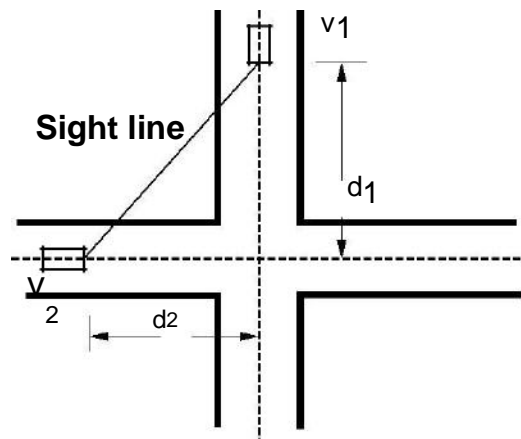

Figure 13:3: Sight distance at intersections

Sight distance at intersections

At intersections where two or more roads meet, visibility should be provided for the drivers approaching the intersection from either side. They should be able to perceive a hazard and stop the vehicle if required. Stopping sight distance for each road can be computed from the design speed. The sight distance should be provided such that the drivers on either side should be able to see each other. This is illustrated in the figure 13:3.

Design of sight distance at intersections may be used on three possible conditions:

Enabling approaching vehicle to change the speed

Enabling approaching vehicle to stop

Enabling stopped vehicle to cross a main road

Horizontal alignment

Design Speed

The design speed, as noted earlier, is the single most important factor in the design of horizontal alignment. The design speed also depends on the type of the road. For e.g., the design speed expected from a National highway will be much higher than a village road, and hence the curve geometry will vary significantly.

The design speed also depends on the type of terrain. A plain terrain can have any geometry, but for the same standard in a hilly terrain requires substantial cutting and filling implying exorbitant costs as well as safety concern due to unstable slopes. Therefore, the design speed is normally reduced for terrains with steep slopes.

For instance, Indian Road Congress (IRC) has classified the terrains into four categories, namely plain, rolling, mountainous, and steep based on the cross slope as given in table 14:1. Based on the type of road and type of terrain the design speed varies. The IRC has suggested desirable or ruling speed as well as minimum suggested design speed and is tabulated in table 14:2. The recommended design speed is given in Table 14:2.

Table 14:1: Terrain classification

Terrain classification	Cross slope (%)
Plain	0-10
Rolling	10-25
Mountainous	25-60
Steep	> 60

Table 14:2: Design speed in km=hr as per IRC (ruling and minimum

Type	Plain	Rolling	Hilly	Steep
NS&SH	100-80	80-65	50-40	40-30
MDR	80-65	65-50	40-30	30-20
ODR	65-50	50-40	30-25	25-20
VR	50-40	40-35	25-20	25-20

Horizontal curve

The presence of horizontal curve imparts centrifugal force which is reactive force acting outward on a vehicle negotiating it. Centrifugal force depends on speed and radius of the horizontal curve and is counteracted to a certain extent by transverse friction between the tyre and pavement surface. On a curved road, this force tends to cause the vehicle to overrun or to slide outward from the centre of road curvature. For proper design of the curve, an understanding of the forces acting on a vehicle taking a horizontal curve is necessary. Various forces acting on the vehicle are illustrated in the figure 14:1.

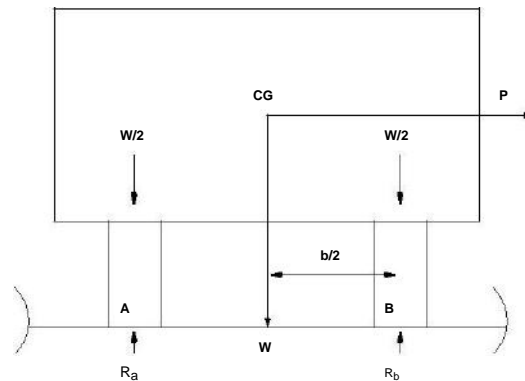

Figure 14:1: Effect of horizontal curve

They are the centrifugal force (P) acting outward, weight of the vehicle (W) acting downward, and the reaction of the ground on the wheels (R_A and R_B). The centrifugal force and the weight is assumed to be from the centre of gravity which is at h units above the ground. Let the wheel base be assumed as b units. The centrifugal force P in $\text{kg}=\text{m}^2$ is given by

$$P = \frac{W v^2}{gR} \quad (14.1)$$

where W is the weight of the vehicle in kg , v is the speed of the vehicle in $\text{m}=\text{sec}$, g is the acceleration due to gravity in $\text{m}=\text{sec}^2$ and R is the radius of the curve in m .

The centrifugal ratio or the impact factor $\frac{P}{W}$ is given by:

$$\frac{P}{W} = \frac{v^2}{gR} \quad (14.2)$$

The centrifugal force has two effects: A tendency to overturn the vehicle about the outer wheels and a tendency for transverse skidding. Taking moments of the forces with respect to the outer wheel when the vehicle is just

about to override,

$$P h = W \frac{b}{2} \quad \text{or} \quad \frac{P}{W} = \frac{b}{2h}$$

At the equilibrium over turning is possible when

$$\frac{v^2}{gR} = \frac{b}{2h}$$

and for safety the following condition must satisfy:

$$\frac{b}{2h} > \frac{v^2}{gR} \quad (14.3)$$

The second tendency of the vehicle is for transverse skidding. i.e. When the centrifugal force P is greater than the maximum possible transverse skid resistance due to friction between the pavement surface and tyre. The transverse skid resistance (F) is given by:

$$F = \frac{F_A + F_B}{f(R_A + R_B)} = fW$$

where F_A and F_B is the fractional force at tyre A and B, R_A and R_B is the reaction at tyre A and B, f is the lateral coefficient of friction and W is the weight of the vehicle. This is counteracted by the centrifugal force (P), and equating:

$$P = fW$$

At equilibrium, when skidding takes place (from equation 14.2)

$$\frac{P}{W} = f = \frac{v^2}{gR}$$

and for safety the following condition must satisfy:

$$f > \frac{v^2}{gR} \quad (14.4)$$

Equation 14.3 and 14.4 give the stable condition for design. If equation 14.3 is violated, the vehicle will overturn at the horizontal curve and if equation 14.4 is violated, the vehicle will skid at the horizontal curve

Analysis of super-elevation

Super-elevation or cant or banking is the transverse slope provided at horizontal curve to counteract the centrifugal force, by raising the outer edge of the pavement with respect to the inner edge, throughout the length of the horizontal curve. When the outer edge is raised, a component of the curve weight will be complimented in counteracting the effect of centrifugal force. In order to and out how much this raising should be, the following analysis may be done. The forces acting on a vehicle while taking a horizontal curve with super elevation is shown in figure 14:2.

Forces acting on a vehicle on horizontal curve of radius R m at a speed of v m/sec² are:

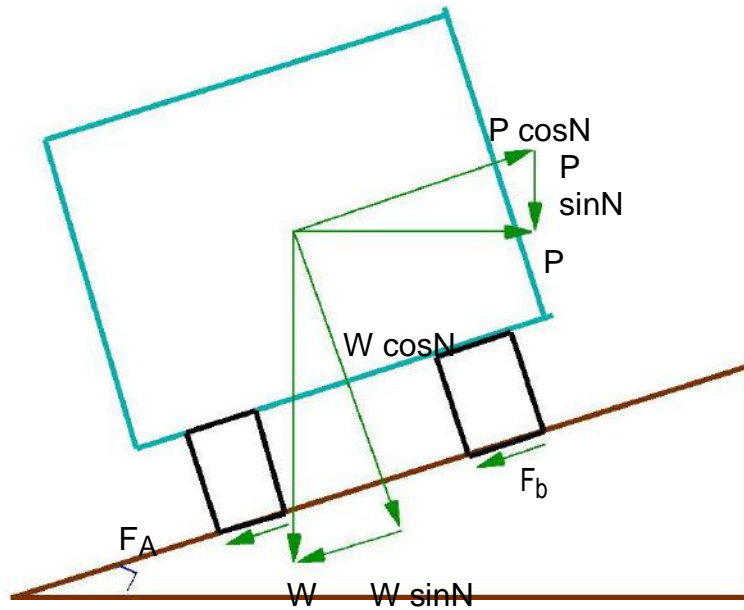

Figure 14:2: Analysis of super-elevation

P the centrifugal force acting horizontally out-wards through the center of gravity,

W is the weight of the vehicle acting down-wards through the center of gravity,

F is the friction force between the wheels and the pavement, along the surface inward.

At equilibrium, by resolving the forces parallel to the surface of the pavement we get,

$$P \sin \theta = W \sin N + F_A + F_B$$

$$W \sin N + f (R_A + R_B)$$

$$W \sin N + f (W \cos N + P \sin N)$$

where W is the weight of the vehicle, P is the centrifugal force, f is the coefficient of friction, θ is the transverse slope due to super elevation. Dividing by $W \cos N$, we get:

P

$$\frac{v^2}{gR} = \frac{\tan N + f}{1 - f \tan N} \quad (14.6)$$

This is an exact expression for super elevation. But normally, $f = 0.15$ and $< 4^\circ$, $f \tan N \approx 1$ and for small N , $\tan N \approx \sin N = E/B = e$, then equation 14.6 becomes:

$$e + f = \frac{v^2}{gR} \quad (14.7)$$

Where, e is the rate of super elevation, f the coefficient of lateral friction 0.15 , v the speed of the vehicle in m/sec , R the radius of the curve in m and $g = 9.8 m/sec^2$.

Three specific cases that can arise from equation 14.7 are as follows:

If there is no friction due to some practical reasons, then $f = 0$ and equation 14.7 becomes

$$e = \frac{v^2}{gR}$$

This results in the situation where the pressure on the outer and inner wheels are same; requiring very high super-elevation e .

12.4 If there is no super-elevation provided due to some practical reasons, then $e = 0$ and equation 14.7 becomes

12.5 $f = \frac{v^2}{gR}$ This results in a very high coefficient of friction.

3 If $e = 0$ and $f = 0.15$ then for safe traveling speed from equation 14.7 is given by $v_b = \sqrt{f g R}$ where v_b is the restricted speed.

Design of super-elevation

For fast moving vehicles, providing higher super elevation without considering coefficient of friction is safe, i.e. centrifugal force is fully counteracted by the weight of the vehicle or super elevation. For slow moving vehicles, providing lower super elevation considering coefficient of friction is safe, i.e. centrifugal force is counteracted by super elevation and coefficient of friction. IRC suggests following design procedure:

Step 1 Find e for 75 percent of design speed, neglecting f , i.e. $e_1 = \frac{(0.75v)^2}{gR}$.

Step 2 If $e_1 \leq 0.07$, then $e = e_1 = \frac{(0.75v)^2}{gR}$, else if $e_1 > 0.07$ go to step 3.

Step 3 Find f_1 for the design speed and max e , i.e. $f_1 = \frac{v^2}{gR} - e = \frac{v^2}{gR} - 0.07$. If $f_1 \leq 0.15$, then the maximum $e = 0.07$ is safe for the design speed, else go to step 4.

Step 4 Find the allowable speed v_a for the maximum $e = 0.07$ and $f = 0.15$, $v_a = \sqrt{0.22gR}$. If $v_a > v$ then the design is adequate, otherwise use speed adopt control measures or look for speed control measures.

Maximum and minimum super-elevation

Depends on

- (a) Slow moving vehicle and
- (b) Heavy loaded trucks with high CG.

IRC specifies a maximum super-elevation of 7 percent for plain and rolling terrain, while that of hilly terrain is 10 percent and urban road is 4 percent. The minimum super elevation is 2-4 percent for drainage purpose, especially for large radius of the horizontal curve.

Attainment of super-elevation

- Elimination of the crown of the cambered section by:
 - Rotating the outer edge about the crown: The outer half of the cross slope is rotated about the crown at a desired rate such that this surface falls on the same plane as the inner half.
 - Shifting the position of the crown: This method is also known as diagonal crown method. Here the position of the crown is progressively shifted outwards, thus increasing the width of the inner half of cross section progressively.
- Rotation of the pavement cross section to attain full super elevation by: There are two methods of attaining super elevation by rotating the pavement
 - Rotation about the center line : The pavement is rotated such that the inner edge is depressed and the outer edge is raised both by half the total amount of super elevation, i.e., by $E=2$ with respect to the centre.
 - Rotation about the inner edge: Here the pavement is rotated raising the outer edge as well as the centre such that the outer edge is raised by the full amount of super elevation with respect to the inner edge.

Radius of Horizontal Curve

The radius of the horizontal curve is an important design aspect of the geometric design. The maximum comfortable speed on a horizontal curve depends on the radius of the curve. Although it is possible to design the curve with maximum super elevation and coefficient of friction, it is not desirable because re-alignment would be required if the design speed is increased in future. Therefore, a ruling minimum radius R_{ruling} can be derived by assuming maximum super elevation and coefficient of friction.

$$R_{\text{ruling}} = \frac{v^2}{g(e + f)} \quad (15.1)$$

Ideally, the radius of the curve should be higher than R_{ruling} . However, very large curves are also not desirable. Setting out large curves in the field becomes difficult. In addition, it also enhances driving strain.

Extra widening

Extra widening refers to the additional width of carriageway that is required on a curved section of a road over and above that required on a straight alignment. This widening is done due to two reasons: the first and most important is the additional width required for a vehicle taking a horizontal curve and the second is due to the tendency of the drivers to ply away from the edge of the carriageway as they drive on a curve. The first is referred as the mechanical widening and the second is called the psychological widening. These are discussed in detail below. Tendency of the drivers to ply away from the edge of the carriageway as they drive on a curve. The first is referred as the mechanical widening and the second is called the psychological widening. These are discussed in detail below.

Mechanical widening

The reasons for the mechanical widening are: When a vehicle negotiates a horizontal curve, the rear wheels follow a path of shorter radius than the front wheels as shown in figure 15.5. This phenomenon is called o - tracking, and has the effect of increasing the effective width of a road space required by the vehicle. Therefore, to provide the same clearance between vehicles traveling in opposite direction on curved roads as is provided on straight sections, there must be extra width of carriageway available. This is an important factor when high proportion of vehicles are using the road. Trailer trucks also need extra carriageway, depending on the type of joint. In addition speeds higher than the design speed causes transverse skidding which requires additional width for safety purpose. The expression for extra width can be derived from the simple geometry of a vehicle at a horizontal curve as shown in figure 15.5. Let R_1 is the radius of the outer track line of the rear wheel, R_2 is the radius of the outer track line of the front wheel l is the distance between the front and rear wheel, n is the number of lanes, then the mechanical widening W_m (refer gure 15:1) is derived below:

$$\begin{aligned} R_2^2 &= R_1^2 + l^2 \\ &= (R_2 - W_m)^2 + l^2 \\ &= R_2^2 - 2R_2W_m + W_m^2 + l^2 \\ 2R_2W_m - W_m^2 &= l^2 \end{aligned}$$

Therefore the widening needed for a single lane road is:

$$W_m = \frac{l^2}{2R_2} \quad (15.2)$$

If the road has n lanes, the extra widening should be provided on each lane. Therefore, the extra widening of a road with n lanes is given by,

$$W_m = \frac{nl^2}{2R} \quad (15.3)$$

Please note that for large radius, $R_2 \approx R$, which is the mean radius of the curve, then W_m is given by:

$$W_m = \frac{nl^2}{2R} \quad (15.4)$$

15.4. Psychological widening

Widening of pavements has to be done for some psychological reasons also. There is a tendency for the drivers to drive close to the edges of the pavement on curves. Some extra space is to be provided for more clearance for the crossing and overtaking operations on curves. IRC proposed an empirical relation for the psychological

widening at horizontal curves W_{ps} :

$$W_{ps} = \frac{v}{2.64P\sqrt{R}} \quad (15.5)$$

Therefore, the total widening needed at a horizontal curve W_e is:

$$\begin{aligned} W_e &= W_m + W_{ps} \\ &= \frac{nl^2}{2R} + \frac{v}{2.64 R} \end{aligned} \quad (15.6)$$

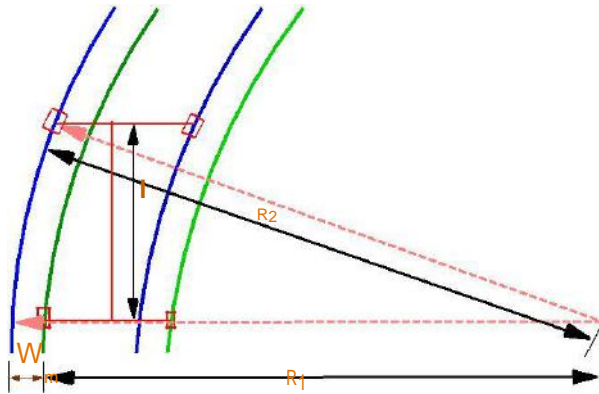

Figure 15:1: Extra-widening at a horizontal curve

Horizontal Transition Curves

Transition curve is provided to change the horizontal alignment from straight to circular curve gradually and has a radius which decreases from infinity at the straight end (tangent point) to the desired radius of the circular curve at the other end (curve point) There are five objectives for providing transition curve and are given below:

- ❖ To introduce gradually the centrifugal force between the tangent point and the beginning of the circular curve, avoiding sudden jerk on the vehicle. This increases the comfort of passengers.
- ❖ To enable the driver turn the steering gradually for his own comfort and security,
- ❖ To provide gradual introduction of super elevation, and
- ❖ To provide gradual introduction of extra widening.
- ❖ To enhance the aesthetic appearance of the road. Type of transition curve

Different types of transition curves are spiral or clothoid, cubic parabola, and Lemniscate. IRC recommends spiral as the transition curve because:

it fulfills the requirement of an ideal transition curve, that is;

rate of change of centrifugal acceleration is consistent (smooth) and

radius of the transition curve is ∞ at the straight edge and changes to R at the curve point (L_s / R^1) and calculation and field implementation is very easy.

Length of transition curve

The length of the transition curve should be determined as the maximum of the following three criteria: rate of change of centrifugal acceleration, rate of change of super elevation, and an empirical formula given by IRC.

1. Rate of change of centrifugal acceleration

At the tangent point, radius is infinity and hence centrifugal acceleration is zero. At the end of the transition, the radius R has minimum value R. The rate of change of centrifugal acceleration should be adopted such that the design should not cause discomfort to the drivers. If c is the rate of change of centrifugal acceleration, it can be written as:

$$\begin{aligned} c &= \frac{v^2}{R} \frac{0}{t} ; \\ &= \frac{v^2}{L_s} ; \\ &= \frac{v^3}{L_s R} ; \end{aligned}$$

Therefore, the length of the transition curve L_{s1} in m is

$$L_{s1} = \frac{v^3}{cR} ; \quad (16.1)$$

where c is the rate of change of centrifugal acceleration given by an empirical formula suggested by by IRC as below:

$$\text{subject to :} \quad c = \frac{80}{75 + 3.6v} ; \quad (16.2)$$

$$c_{min} = 0.5;$$

$$c_{max} = 0.8;$$

2. Rate of introduction of super-elevation

Raise (E) of the outer edge with respect to inner edge is given by $E = eB = e(W + W_e)$. The rate of change

of this raise from 0 to E is achieved gradually with a gradient of 1 in N over the length of the transition curve (typical range of N is 60-150). Therefore, the length of the transition curve L_{S2} is:

$$L_{S2} = N e(W + W_e) \quad (16.3)$$

3. By empirical formula

IRC suggest the length of the transition curve is minimum for a plain and rolling terrain:

$$L_{s3} = \frac{35v^2}{R} \quad (16.4)$$

and for steep and hilly terrain is:

$$L_{s3} = \frac{12.96v^2}{R} \quad (16.5)$$

and the shift s as:

$$s = \frac{L_s^2}{24R} \quad (16.6)$$

The length of the transition curve L_S is the maximum of equations 16.1, 16.3 and 16.4or16.5, i.e.

$$L_S = \text{Max} : (L_{S1} ; L_{S2} ; L_{S3}) \quad (16.7)$$

Setback Distance

Setback distance m or the clearance distance is the distance required from the centerline of a horizontal curve to an obstruction on the inner side of the curve to provide adequate sight distance at a horizontal curve. The setback distance depends on:

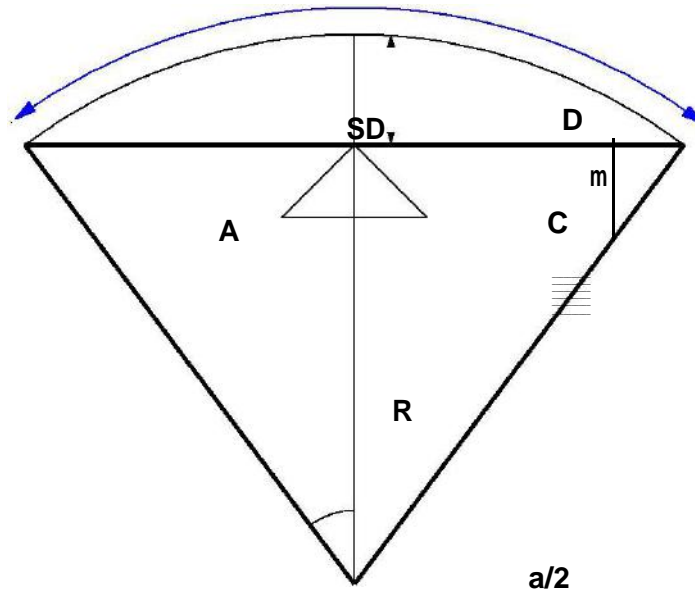

Figure 16:1: Set-back for single lane roads ($L_S < L_C$)

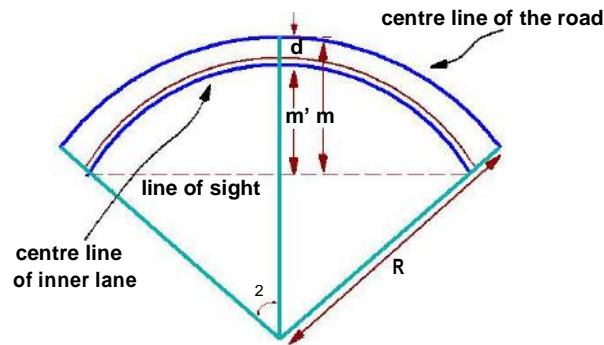

Figure 16:2: Set-back for multi-lane roads ($L_S < L_C$)

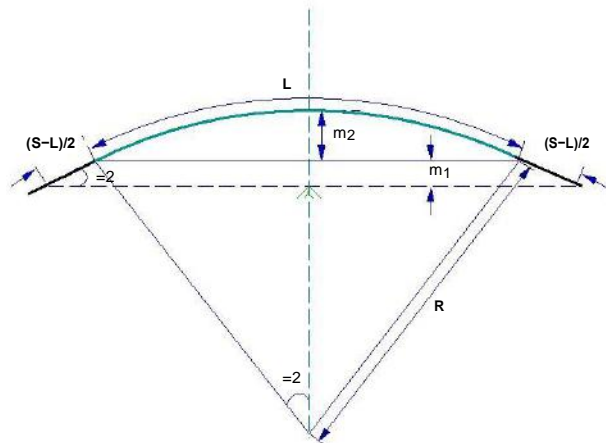

Figure 16:3: Set back for single lane roads ($L_s < L_c$)

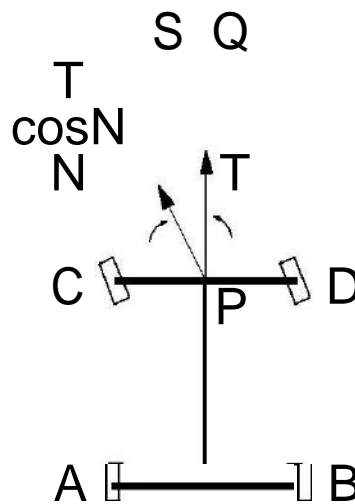

Figure 16:4: Curve resistance

Curve Resistance

When the vehicle negotiates a horizontal curve, the direction of rotation of the front and the rear wheels are different. The front wheels are turned to move the vehicle along the curve, whereas the rear wheels seldom turn. This is illustrated in figure 16:4. The rear wheels exert a tractive force T in the PQ direction. The tractive force available on the front wheels is $T \cos N$ in the PS direction as shown in the figure 16:4. This is less than the actual tractive force, T applied. Hence, the loss of tractive force for a vehicle to negotiate a horizontal curve is:

$$CR = T \sin N \quad (16.14)$$

Gradient

Gradient is the rate of rise or fall along the length of the road with respect to the horizontal. While

aligning a highway, the gradient is decided for designing the vertical curve. Before finalizing the gradients, the construction cost, vehicular operation cost and the practical problems in the site also has to be considered. Usually steep gradients are avoided as far as possible because of the difficulty to climb and increase in the construction cost. More about gradients are discussed below.

Effect of gradient

The effect of long steep gradient on the vehicular speed is considerable. This is particularly important in roads where the proportion of heavy vehicles is significant. Due to restrictive sight distance at uphill gradients the speed of traffic is often controlled by these heavy vehicles. As a result, not only the operating costs of the vehicles are increased, but also capacity of the roads will have to be reduced. Further, due to high differential speed between heavy and light vehicles, and between uphill and downhill gradients, accidents abound in gradients.

Representation of gradient

The positive gradient or the ascending gradient is denoted as +n and the negative gradient as n. The deviation angle N is: when two grades meet, the angle which measures the change of direction and is given by the algebraic difference between the two grades $(n_1 - n_2) = n_1 + n_2 = i_1 + i_2$. Example: 1 in 30 = 3.33% 2° is a steep gradient, while 1 in 50 = 2% $1^\circ 10'$ is a gradient. The gradient representation is illustrated in the figure 17:1.

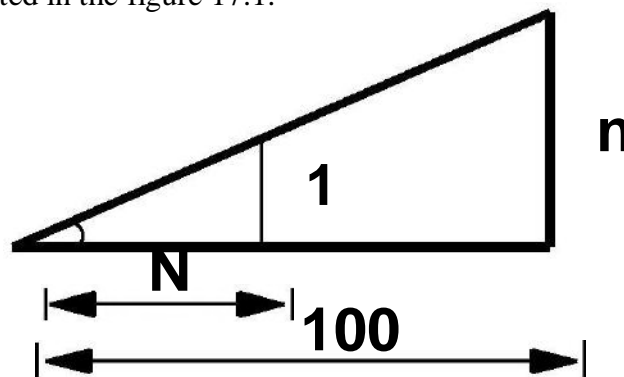

Figure 17:1: Representation of gradient

Terrain	Ruling	Limiting	Exceptional
Plain/Rolling	3.3	5.0	6.7
Hilly	5.0	6.0	7.0
Steep	6.0	7.0	8.0

Table 17:1: IRC Specifications for gradients for different roads

Types of gradient

Many studies have shown that gradient up to seven percent can have considerable effect on the speeds of the passenger cars. On the contrary, the speeds of the heavy vehicles are considerably

reduced when long gradients as at as two percent is adopted. Although, gradients are desirable, it is evident that the cost of construction will also be very high. Therefore, IRC has specified the desirable gradients for each terrain. However, it may not be economically viable to adopt such gradients in certain locations, steeper gradients are permitted for short duration. Different types of grades are discussed below and the recommended type of gradients for each type of terrain and type of gradient is given in table 17:1.

Ruling gradient, limiting gradient, exceptional gradient and minimum gradient are some types of gradients which are discussed below.

Ruling gradient

The ruling gradient or the design gradient is the maximum gradient with which the designer attempts to design the vertical profile of the road. This depends on the terrain, length of the grade, speed, pulling power of the vehicle and the presence of the horizontal curve. In terrain, it may be possible to provide at gradients, but in hilly terrain it is not economical and sometimes not possible also. The ruling gradient is adopted by the designer by considering a particular speed as the design speed and for a design vehicle with standard dimensions. But our country has a heterogeneous traffic and hence it is not possible to lay down precise standards for the country as a whole. Hence IRC has recommended some values for ruling gradient for different types of terrain.

Limiting gradient

This gradient is adopted when the ruling gradient results in enormous increase in cost of construction. On rolling terrain and hilly terrain it may be frequently necessary to adopt limiting gradient. But the length of the limiting gradient stretches should be limited and must be sandwiched by either straight roads or easier grades.

Exceptional gradient

Exceptional gradient are very steeper gradients given at unavoidable situations. They should be limited for short stretches not exceeding about 100 meters at a stretch. In mountainous and steep terrain, successive exceptional gradients must be separated by a minimum 100 metre length gentler gradient. At hairpin bends, the gradient is restricted to 2.5%.

Critical length of the grade

The maximum length of the ascending gradient which a loaded truck can operate without undue reduction in speed is called critical length of the grade. A speed of 25 kmph is a reasonable value. This value depends on the size, power, load, grad-ability of the truck, initial speed, nal desirable minimum speed etc.

Minimum gradient

This is important only at locations where surface drainage is important. Camber will take care of the lateral drainage. But the longitudinal drainage along the side drains requires some slope for smooth flow of water. Therefore minimum gradient is provided for drainage purpose and it depends on the rain fall, type of soil and other site conditions. A minimum of 1 in 500 may be sufficient for concrete drain and 1 in 200 for open soil drains are found to give satisfactory performance..

Creeper lane

When the uphill climb is extremely long, it may be desirable to introduce an additional lane so as to allow slow ascending vehicles to be removed from the main stream so that the fast moving vehicles are not affected. Such a newly introduced lane is called creeper lane. There are no hard and fast rules as when to introduce a creeper lane. But generally, it can be said that it is desirable to provide a creeper lane when the speed of the vehicle gets reduced to half the design speed. When there is no restrictive sight distance to reduce the speed of the approaching vehicle, the additional lane may be initiated at some distance uphill from the beginning of the slope. But when the restrictions are responsible for the lowering of speeds, obviously the lane should be initiated at a point closer to the bottom of the hill. Also the creeper lane should end at a point well beyond the hill crest, so that the slow moving vehicles can return back to the normal lane without any danger. In addition, the creeper lane should not end suddenly, but only in a tapered manner for efficient as well as safer transition of vehicles to the normal lane.

Grade compensation

While a vehicle is negotiating a horizontal curve, if there is a gradient also, then there will be increased resistance to traction due to both curve and the gradient. In such cases, the total resistance should not exceed the resistance due to gradient specified. For the design, in some cases this maximum value is limited to the ruling gradient

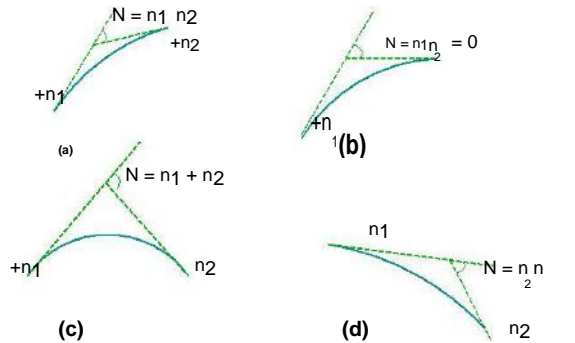

Figure 17:2: Types of summit curves

and in some cases as limiting gradient. So if a curve need to be introduced in a portion which has got the maximum permissible gradient, then some compensation should be provided so as to decrease the gradient for overcoming the tractive loss due to curve. Thus grade compensation can be defined as the reduction in gradient at the horizontal curve because of the additional tractive force required due to curve resistance ($T T \cos N$), which is intended to o set the extra tractive force involved at the curve. IRC gave the following specification for the grade compensation.

1. Grade compensation is not required for grades flatter than 4% because the loss of tractive force is negligible.
2. Grade compensation is $\frac{30+R}{R}$ %, where R is the radius of the horizontal curve in meters.
3. The maximum grade compensation is limited to $\frac{75}{R}$ %

Summit curve

Summit curves are vertical curves with gradient upwards. They are formed when two gradients meet as

Illustrated in figure 17:2 in any of the following four ways:

- 2.3.2 When a positive gradient meets another positive gradient [figure 17:2a].
- 2.3.3 When positive gradient meets a at gradient [figure 17:2b]. .
- 2.3.4 When an ascending gradient meets a descending gradient [figure 17:2c]. .
- 2.3.5 When a descending gradient meets another descending gradient [figure 17:2d]. .

Type of Summit Curve

Many curve forms can be used with satisfactory results, the common practice has been to use parabolic curves in summit curves. This is primarily because of the ease with it can be laid out as well as allowing a comfortable transition from one gradient to another. Although a circular curve of equal sight distance at every point on the curve, for very small deviation angles a circular curve and parabolic curves are almost congruent. Furthermore, the use of parabolic curves was found to give excellent riding comfort.

Minimum gradient

This is important only at locations where surface drainage is important. Camber will take care of the lateral drainage. But the longitudinal drainage along the side drains requires some slope for smooth flow of water. Therefore minimum gradient is provided for drainage purpose and it depends on the rain fall, type of soil and other site conditions. A minimum of 1 in 500 may be sufficient for concrete drain and 1 in 200 for open soil drains are found to give satisfactory performance..

Gradient

Gradient is the rate of rise or fall along the length of the road with respect to the horizontal. While aligning a highway, the gradient is decided for designing the vertical curve. Before finalizing the gradients, the construction cost, vehicular operation cost and the practical problems in the site also has to be considered. Usually steep gradients are avoided as far as possible because of the difficulty to climb and increase in the construction cost. More about gradients are discussed below.

Figure 17:4: Length of summit curve ($L < S$)

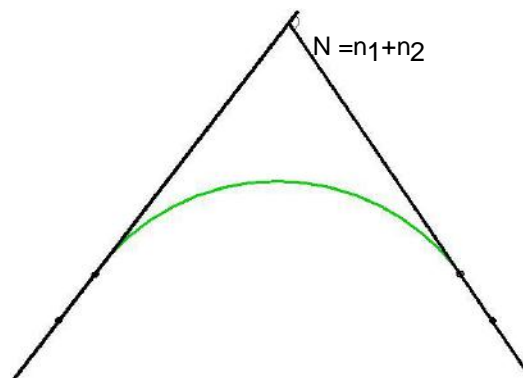

Valley curve

Valley curve or sag curves are vertical curves with convexity downwards. They are formed when two gradients meet as illustrated in figure 18:1 in any of the following four ways:

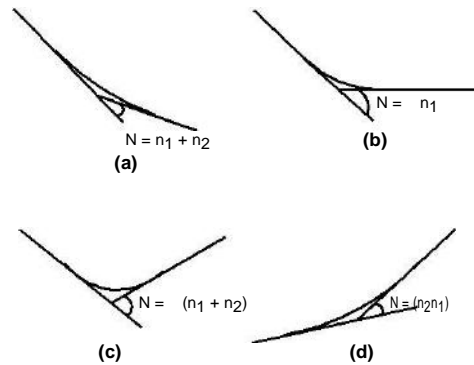

Figure 18:1: Types of valley curve

1. When a descending gradient meets another descending gradient [figure 18:1a].
2. When a descending gradient meets a horizontal gradient [figure 18:1b].
3. When a descending gradient meets an ascending gradient [figure 18:1c].
4. When an ascending gradient meets another ascending gradient [figure 18:1d].

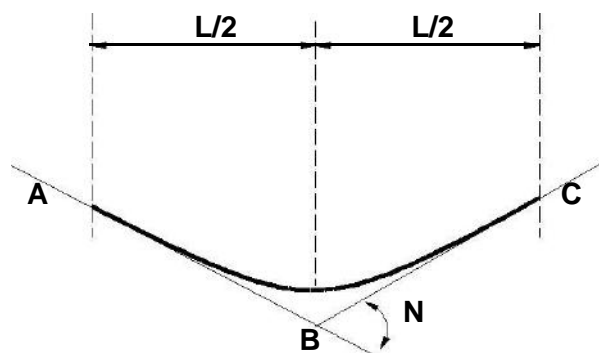

Figure 18:2: Valley curve details

Design considerations

There is no restriction to sight distance at valley curves during day time. But visibility is reduced during night. In the absence or inadequacy of street light, the only source for visibility is with the help of headlights. Hence valley curves are designed taking into account of headlight distance. In

valley curves, the centrifugal force will be acting downwards along with the weight of the vehicle, and hence impact to the vehicle will be more. This will result in jerking of the vehicle and cause discomfort to the passengers. Thus the most important design factors considered in valley curves are: (1) impact-free movement of vehicles at design speed and (2) availability of stopping sight distance under headlight of vehicles for night driving.

For gradually introducing and increasing the centrifugal force acting downwards, the best shape that could be given for a valley curve is a transition curve. Cubic parabola is generally preferred in vertical valley curves. See figure 18:2.

During night, under headlight driving condition, sight distance reduces and availability of stopping sight distance under head light is very important. The head light sight distance should be at least equal to the stopping sight distance. There is no problem of overtaking sight distance at night since the other vehicles with headlights could be seen from a considerable distance.

Length of the valley curve

The valley curve is made fully transitional by providing two similar transition curves of equal length. The transitional curve is set out by a cubic parabola $y = bx^3$ where $b = \frac{2N}{L^3}$. The length of the valley transition curve is designed based on two criteria:

1. Comfort criteria; that is allowable rate of change of centrifugal acceleration is limited to a comfortable level of about 0.6 m/sec^3 .
2. Safety criteria; that are the driver should have adequate headlight sight distance at any part of the country.

Comfort criteria

The length of the valley curve based on the rate of change of centrifugal acceleration that will ensure comfort: Let c is the rate of change of acceleration, R the minimum radius of the curve, v is the design speed and t is

the time, then c is given as:

$$\begin{aligned}
 c &= \frac{v^2}{R} \\
 &= \frac{v^2}{\frac{L}{v}} \\
 &= \frac{v^3}{LR} \\
 L &= \frac{v^3}{cR}
 \end{aligned}
 \tag{18.1}$$

For a cubic parabola, the value of R for length L_s is given by:

$$R = \frac{L}{N} \tag{18.2}$$

where L is the total length of valley curve, N is the deviation angle in radians or tangent of the deviation angle or the algebraic difference in grades, and c is the allowable rate of change of centrifugal acceleration which may be taken as 0.6 m/sec^3 .

Safety criteria

Length of the valley curve for headlight distance may be determined for two conditions: (1) length of the valley curve greater than stopping sight distance and (2) length of the valley curve less than the stopping sight distance.

Case 1 Length of valley curve greater than stopping sight distance ($L > S$)

The total length of valley curve L is greater than the stopping sight distance SSD. The sight distance available will be minimum when the vehicle is in the lowest point in the valley. This is because the beginning of the curve will have infinite radius and the bottom of the curve will have minimum radius which is a property of the transition curve. The case is shown in figure 18:3. From the geometry of the figure, we have:

$$\begin{aligned}
 h_1 + S \tan N &= aS^2 \\
 &= \frac{N S^2}{2L} \\
 L &= \frac{N S^2}{2h_1 + 2S \tan N}
 \end{aligned}
 \tag{18.4}$$

where N is the deviation angle in radians, h_1 is the height of headlight beam, θ is the head beam inclination in degrees and S is the sight distance. The inclination is 1 degree.

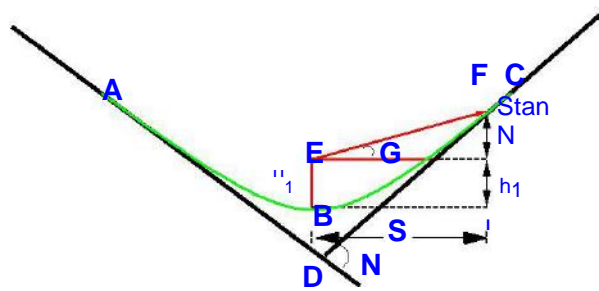

Figure 18:3: Valley curve, case 1, $L > S$

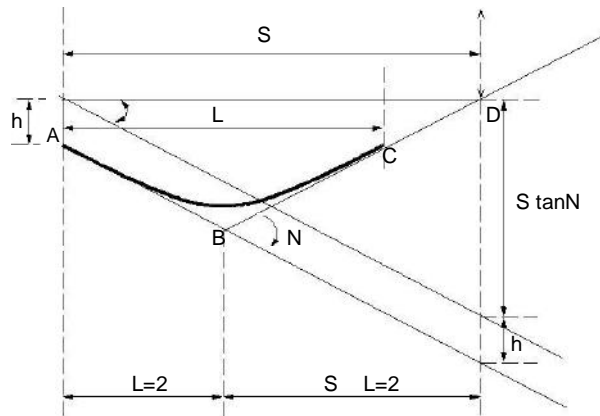

Figure 18:4: Valley curve, case 2, $S > L$

Case 2 Length of valley curve less than stopping sight distance ($L < S$)

The length of the curve L is less than SSD . In this case the minimum sight distance is from the beginning of the curve. The important points are the beginning of the curve and the bottom most part of the curve. If the vehicle is at the bottom of the curve, then its headlight beam will reach far beyond the endpoint of the curve whereas, if the vehicle is at the beginning of the curve, then the headlight beam will hit just outside the curve. Therefore, the length of the curve is derived by assuming the vehicle at the beginning of the curve. The case is shown in figure 18:4.

From the figure,

$$h_1 + s \tan N = S_2 \frac{N}{L}$$

$$L = 2S \frac{2h_1 + 2S \tan N}{N} \quad (18.5)$$

Note that the above expression is approximate and is satisfactory because in practice, the gradients are very small and is acceptable for all practical purposes. We will not be able to know prior to which case to be adopted. Therefore both has to be calculated and the one which satisfies the condition is adopted.

UNIT III

Traffic Engineering & Regulation

Overview

Unlike many other disciplines of the engineering, the situations that are interesting to a traffic engineer cannot be reproduced in a laboratory. Even if road and vehicles could be set up in large laboratories, it is impossible to simulate the behavior of drivers in the laboratory. Therefore, traffic stream characteristics need to be collected only from the field. There are several methods of data collection depending on the need of the study and some important ones are described in this chapter.

Data requirements

The most important traffic characteristics to be collected from the field include speed, travel time, flow and density. Some cases, spacing and headway are directly measured. In addition, the occupancy, i.e. percentage of time a point on the road is occupied by vehicles is also of interest. The measurement procedures can be classified based on the geographical extent of the survey into five categories: (a) measurement at point on the road, (b) measurement over a short section of the road (less than 500 meters) (c) measurement over a length of the road (more than about 500 meters) (d) wide area samples obtained from number of locations, and (e) the use of an observer moving in the traffic stream. In each category, numerous data collection are there. However, important and basic methods will be discussed.

Measurements at a point

The most important point measurement is the vehicle volume count. Data can be collected manually or automatically. In manual method, the observer will stand at the point of interest and count the vehicles with the help of hand tallies. Normally, data will be collected for short interval of 5 minutes or 15 minutes etc. and for each type of vehicles like cars, two wheelers, three wheelers, LCV, HCV, multi axle trucks, non motorized traffic like bullock cart, hand cart etc. From the flow data, flow and headway can be derived.

Modern methods include the use of inductive loop detector, video camera, and many other technologies. These methods help to collect accurate information for long duration. In video cameras, data is collected from the field and is then analyzed in the lab for obtaining results. Radars and microwave detectors are used to obtain the speed of a vehicle at a point. Since no length is involved, density cannot be obtained by measuring at a point.

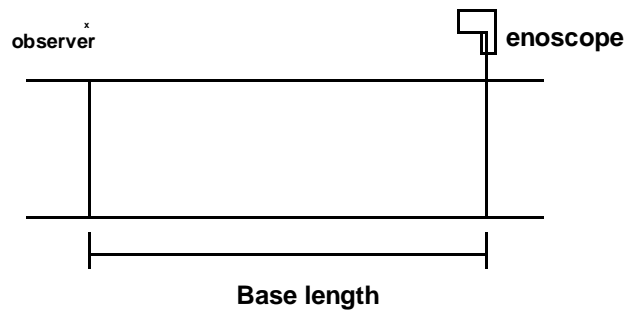

Figure 32:1: Illustration of measurement over short section using endoscope

Measurements over short section

The main objective of this study is to find the spot speed of vehicles. Manual methods include the use of enoscope. In this method a base length of about 30-90 meters is marked on the road. Enoscope is placed at one end and observer will stand at the other end. He could see the vehicle passing the farther end through enoscope and starts the stop watch. Then he stops the stop watch when the vehicle passes in front of him. The working of the enoscope is shown in figure 32:1.

An alternative method is to use pressure contact tube which gives a pressure signal when vehicle moves at either end. Another most widely used method is inductive loop detector which works on the principle of magnetic inductance. Road will be cut and a small magnetic loop is placed. When the metallic content in the vehicle passes over it, a signal will be generated and the count of the vehicle can be found automatically. The advantage of this detector is that the counts can be obtained throughout the life time of the road. However, chances of errors are possible because noise signals may be generated due to heavy vehicle passing adjacent lanes. When dual loops are used and if the spacing between them is known then speed also can be calculated in addition to the vehicle count.

Measurements over long section

This is normally used to obtain variations in speed over a stretch of road. Usually the stretch will be having a length more than 500 meters. We can also get density. Most traditional method uses aerial photography. From a single frame, density can be measured, but not speed or volumes. In time lapse photography, several frames are available. If several frames are obtained over short time intervals, speeds can be measured from the distance covered between the two frames and time interval between them.

Moving observer method for stream measurement

Determination of any of the two parameters of the traffic will provide the third one by the equation $q = u \cdot k$. Moving observer method is the most commonly used method to get the relationship between the fundamental stream characteristics. In this method, the observer moves in the traffic stream unlike all other previous methods.

Consider a stream of vehicles moving in the north bound direction. Two different cases of motion can be considered. The rest case considers the traffic stream to be moving and the observer to be stationary. If n_o is the number of vehicles overtaking the observer during a period, t , and then flow

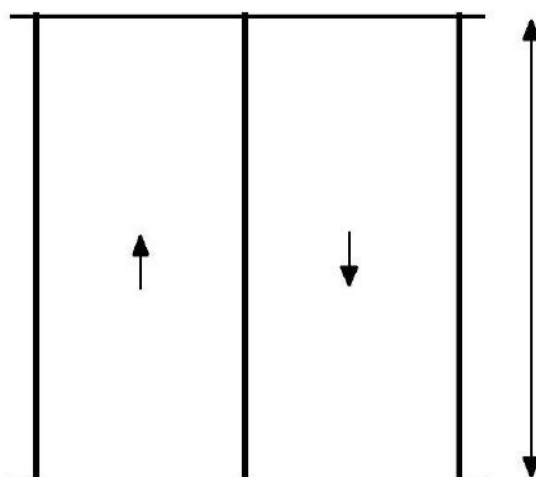

Figure 32:2: Illustration of moving observer method

$$n_0 = qt \quad (32.1)$$

The second case assumes that the stream is stationary and the observer moves with speed v_o . If n_p is the number of vehicles overtaken by observer over a length l , then by definition, density k is the density

$$n_p = kl \quad (32.2)$$

or

$$n_p = k \cdot v_o \cdot t \quad (32.3)$$

Where v_o is the speed of the observer and t is the time taken for the observer to cover the road stretch. Now consider the case when the observer is moving within the stream. In that case m_o vehicles will overtake the observer and m_p vehicles will be overtaken by the observer in the test vehicle. Let the difference m is given by $m_o - m_p$, then from equation 32.5 and equation 32.7,

$$m = q \cdot t - k \cdot v_o \cdot t \quad (32.4)$$

This equation is the basic equation of moving observer method, which relates q ; k to the counts m , t and v_o that can be obtained from the test. However, we have two unknowns, q and k , but only one equation. For generating another equation, the test vehicle is run twice once with the traffic stream and another one against traffic stream.

Where, a ; w denotes against and with traffic flow. It may be noted that the sign of equation 32.5 is negative, because test vehicle moving in the opposite direction can be considered as a case when the test vehicle is moving in the stream with negative velocity. Further, in this case, all the vehicles will be overtaking, since it is moving with negative speed. In other words, when the test vehicle moves in the opposite direction, the observer simply counts the number of vehicles in the opposite direction. Adding equation 32.5 and 32.5, we will get the first parameter of the stream, namely the flow (q)

Rewriting the above equation, we get the second parameter of the traffic flow, namely the mean speed v_s and

Thus two parameters of the stream can be determined. Knowing the two parameters the third parameter of traffic density (k) can be found out as

$$k = \frac{q}{v_s} \quad (32.7)$$

For increase accuracy and reliability, the test is performed a number of times and the average results are to be taken.

Traffic signs

Traffic control device is the medium used for communicating between traffic engineer and road users. Unlike other modes of transportation, there is no control on the drivers using the road. Here traffic control devices come to the help of the traffic engineer. The major types of traffic control devices used are- traffic signs, road markings, traffic signals and parking control. This chapter discusses traffic control signs. Different types of traffic signs are regulatory signs, warning signs and informative signs.

Requirements of traffic control devices

5. **The control device should fulfill a need:** Each device must have a specific purpose for the safe and efficient operation of traffic flow.
6. **It should command attention from the road users:** This affects the design of signs. For commanding attention, proper visibility should be there. Also the sign should be distinctive and clear. The sign should be placed in such a way that the driver requires no extra effort to see the sign.
7. **It should convey a clear, simple meaning:** Clarity and simplicity of message is essential for the driver to properly understand the meaning in short time. The use of color, shape and legend as codes becomes important in this regard. The legend should be kept short and simple so that even a less educated driver could understand the message in less time.
8. **Road users must respect the signs:** Respect is commanded only when the drivers are conditioned to expect that all devices carry meaningful and important messages. Over use, misuse and confusing messages of devices tends the drivers to ignore them.
9. **The control device should provide adequate time for proper response from the road users:** This is again related to the design aspect of traffic control devices. The sign boards should be placed at a distance such that the driver could see it and gets sufficient time to respond to the situation. For example, the STOP sign which is always placed at the stop line of the intersection should be visible for at least one safe stopping sight distance away from the stop line.

Communication tools

A number of mechanisms are used by the traffic engineer to communicate with the road user. These mechanisms recognize certain human limitations, particularly eyesight. Messages are conveyed through the following elements.

Color: It is the first and most easily noticed characteristics of a device. Usage of different colors for different signs is important. The most commonly used colors are red, green, yellow, black, blue, and brown. These are used to code certain devices and to reinforce specific messages. Consistent use of colors helps the drivers to identify the presence of sign board ahead.

Shape: It is the second element discerned by the driver next to the color of the device. The categories of shapes normally used are circular, triangular, rectangular, and diamond shape. Two exceptional shapes used in traffic signs are octagonal shape for STOP sign and use of inverted triangle for GIVE WAY (YIELD) sign. Diamond shape signs are not generally used in India.

Legend: This is the last element of a device that the driver comprehends. This is an important aspect in the case of traffic signs. For the easy understanding by the driver, the legend should be short, simple and specific so that it does not divert the attention of the driver. Symbols are normally used as legends so that even a person unable to read the language will be able to understand that. There is no need of it in the case of traffic signals and road markings.

Pattern: It is normally used in the application of road markings, complementing traffic signs. Generally solid, double solid and dotted lines are used. Each pattern conveys different type of meaning. The frequent and consistent use of pattern to convey information is recommended so that the drivers get accustomed to the different types of markings and can instantly recognize them.

Types of traffic signs

There is several hundreds of traffic signs available covering wide variety of traffic situations. They can be classified into three main categories.

Regulatory signs: These signs require the driver to obey the signs for the safety of other road users.

Warning signs: These signs are for the safety of oneself who is driving and advice the drivers to obey these signs.

Informative signs: These signs provide information to the driver about the facilities available ahead, and the route and distance to reach the specific destinations

In addition special type of traffic sign namely work zone signs are also available. These type of signs are used to give warning to the road users when some construction work is going on the road. They are placed only for short duration and will be removed soon after the work is over and when the road is brought back to its normal condition. The first three signs will be discussed in detail below.

Regulatory signs

These signs are also called mandatory signs because it is mandatory that the drivers must obey these signs. If the driver fails to obey them, the control agency has the right to take legal action against the driver. These signs are primarily meant for the safety of other road users. These signs have generally black legend on a white background. They are circular in shape with red borders. The regulatory signs can be further classified into :

1. **Right of way series:** These include two unique signs that assign the right of way to the selected approaches of an intersection. They are the STOP sign and GIVE WAY sign For example, when one minor road and major road meets at an intersection, preference should be given to the vehicles passing through the major road. Hence the give way sign board will be placed on the minor road to inform the driver on the minor road that he should give way for the vehicles on the major road. In case two major roads are meeting, then the traffic engineer decides based on the traffic on which approach the sign board has to be placed. Stop sign is another example of regulatory signs that comes in right of way series which requires the driver to stop the vehicle at the stop line.
2. **Speed series:** Number of speed signs may be used to limit the speed of the vehicle on the road. They include typical speed limit signs, truck speed, minimum speed signs etc. Speed

limit signs are placed to limit the speed of the vehicle to a particular speed for many reasons. Separate truck speed limits are applied on high speed roadways where heavy commercial vehicles must be limited to slower speeds than passenger cars for safety reasons. Minimum speed limits are applied on high speed roads like expressways, freeways etc. where safety is again a predominant reason. Very slow vehicles may present hazard to themselves and other vehicles also.

3. **Movement series:** They contain a number of signs that aspect specific vehicle maneuvers. These include turn signs, alignment signs, exclusion signs, one way signs etc. Turn signs include turn prohibitions and lane use control signs. Lane use signs make use of arrows to specify the movements which all vehicles in the lane must take. Turn signs are used to safely accommodate turns in un signalized intersections.
4. **Parking series:** They include parking signs which indicate not only parking prohibitions or restrictions, but also indicate places where parking is permitted, the type of vehicle to be parked, duration for parking etc.
5. **Pedestrian series:** They include both legend and symbol signs. These signs are meant for the safety of pedestrians and include signs indicating pedestrian only roads, pedestrian crossing sites etc.
6. **Miscellaneous:** Wide variety of signs that are included in this category are: a "KEEP OFF MEDIAN" sign, signs indicating road closures, signs restricting vehicles carrying hazardous cargo or substances, signs indicating vehicle weight limitations etc.

Some examples of the regulatory signs are shown in figure 36:1. They include a stop sign, give way sign, signs for no entry, sign indicating prohibition for right turn, vehicle width limit sign, speed limit sign etc.

Warning signs

Warning signs or cautionary signs give information to the driver about the impending road condition. They advise the driver to obey the rules. These signs are meant for the own safety of drivers. They call for extra vigilance from the part of drivers. The color convention used for this type of signs is that the legend will be black

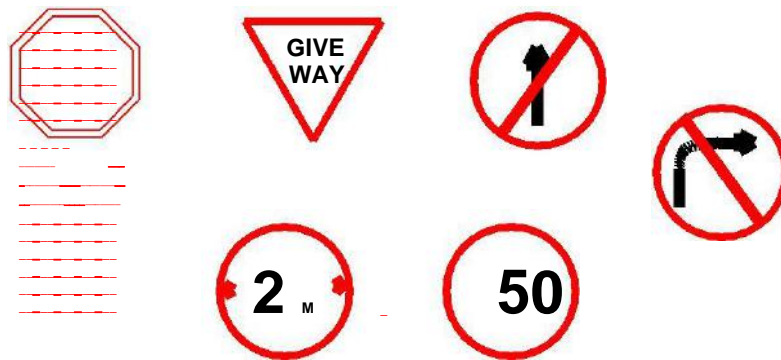

Figure 36:1: Examples of regulatory signs (stop sign, give way sign, signs for no entry, sign indicating prohibition for right turn, vehicle width limit sign, speed limit sign)

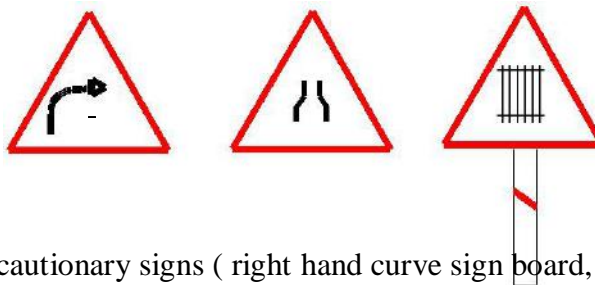

Figure 36:2: Examples of cautionary signs (right hand curve sign board, signs for narrow road, sign indicating railway track ahead)

in color with a white background. The shape used is upward triangular or diamond shape with red borders. Some of the examples for this type of signs are given in g 36:2 and includes right hand curve sign board, signs for narrow road, sign indicating railway track ahead etc.

Informative signs

Informative signs also called guide signs are provided to assist the drivers to reach their desired destinations. These are predominantly meant for the drivers who are unfamiliar to the place. The guide signs are redundant for the users who are accustomed to the location.

Some of the examples for these type of signs are route markers, destination signs, mile posts, service in-formation, recreational and cultural interest area signing etc. Route markers are used to identify numbered highways. They have designs that are distinctive and unique. They are written black letters on yellow back-ground. Destination signs are used to indicate the direction to the critical destination points, and to mark important intersections. Distance in kilometers is sometimes

marked to the right side of the destination. They are, in general, rectangular with the long dimension in the horizontal direction. They are color coded as white letters with green background.

Mile posts are provided to inform the driver about the progress along a route to reach his destination

Road markings

The essential purpose of road markings is to guide and control traffic on a highway. They supplement the function of traffic signs. The markings serve as a psychological barrier and signify the delineation of traffic path and its lateral clearance from traffic hazards for the safe movement of traffic. Hence they are very important to ensure the safe, smooth and harmonious flow of traffic. Various types of road markings like longitudinal markings, transverse markings, object markings and special markings to warn the driver about the hazardous locations in the road etc. will be discussed in detail

Transverse markings

Transverse markings are marked across the direction of traffic. They are marked at intersections etc. The site conditions play a very important role. The type of road marking for a particular intersection depends on several variables such as speed characteristics of traffic, availability of space etc. Stop line markings, markings for pedestrian crossing, direction arrows, etc. are some of the markings on approaches to intersections.

Warning lines

Warning lines warn the drivers about the obstruction approaches. They are marked on horizontal and vertical curves where the visibility is greater than prohibitory criteria specified for no overtaking zones. They are broken lines with 6 m length and 3 m gap.

Pedestrian crossings are provided at places where the conflict between vehicular and pedestrian traffic is severe. The site should be selected that there is less inconvenience to the pedestrians and also the vehicles are not interrupted too much. At intersections, the pedestrian crossings should be preceded by a stop line at a distance of 2 to 3m for un signalized intersections and at a distance of one meter for signalized intersections. Most commonly used pattern for pedestrian crossing is Zebra crossing consisting of equally spaced white strips of 500 mm wide

Classification of road markings

The road markings are defined as lines, patterns, words or other devices, except signs, set into applied or attached to the carriageway or kerbs or to objects within or adjacent to the carriageway, for controlling, warning, guiding and informing the users. The road markings are classified as longitudinal markings, transverse markings, object markings, word messages, marking for parking's, marking at hazardous locations etc.

Longitudinal markings

Longitudinal markings are placed along the direction of traffic on the roadway surface, for the purpose of indicating to the driver, his proper position on the roadway. Some of the guiding principles in longitudinal markings are also discussed below.

Longitudinal markings are provided for separating traffic flow in the same direction and the predominant color used is white. Yellow color is used to separate the traffic flow in opposite direction and also to separate the pavement edges. The lines can be either broken, solid or double solid. Broken lines are permissive in character and allow crossing with discretion, if track situation permits. Solid lines are restrictive in character and does not allow crossing except for entry or exit from a side road or premises or to avoid a stationary obstruction. Double solid lines indicate severity in restrictions and should not be crossed except in case of emergency. There can also be a combination of solid and broken lines. In such a case, a solid line may be crossed with discretion, if the broken line of the combination is nearer to the direction of travel. Vehicles from the opposite directions are not permitted to cross the line. Different types of longitudinal markings are centre line, traffic lanes, no passing zone, warning lines, border or edge lines, bus lane markings, cycle lane markings.

Centre line separates the opposing streams of traffic and facilitates their movements. Usually no centre line is provided for roads having width less than 5 m and for roads having more than four lanes. The centre line may be marked with single broken line, single solid line, double broken line, or double solid line depending upon the road and traffic requirements.

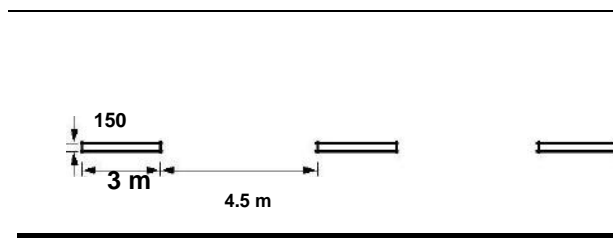

Figure 37:1: Centre line marking for a two lane road

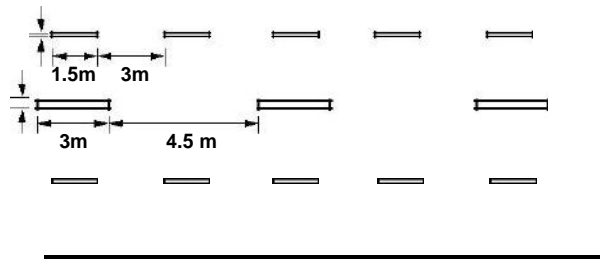

Figure 37:2: Centre line and lane marking for a four lane road

Centre line

Centre line separates the opposing streams of traffic and facilitates their movements. Usually no centre line is provided for roads having width less than 5 m and for roads having more than four lanes. The centre line may be marked with single broken line, single solid line, double broken line, or double solid line depending upon the road and traffic requirements. On urban roads with less than four lanes, the centre line may be single broken line segments of 3 m long and 150 mm wide. The broken lines are placed with 4.5 m gaps (figure 37:1). On curves and near intersections, gap shall be reduced to 3 meters. On undivided urban roads with at least two traffic lanes in each direction, the centre line marking may be a single solid line of 150 mm wide as in figure 37:2, or double solid line of 100 mm wide separated by a space of 100 mm as shown in figure 37:3. The centre barrier line marking for four lane road is shown in figure 37:4.

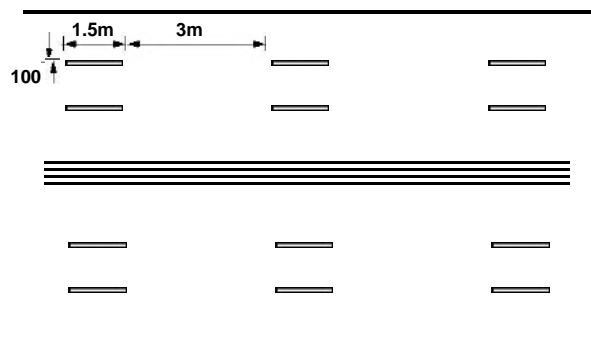

Figure 37:3: Double solid line for a two lane road

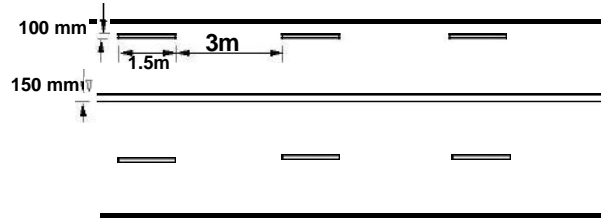

Figure 37:4: Centre barrier line marking for four lane road

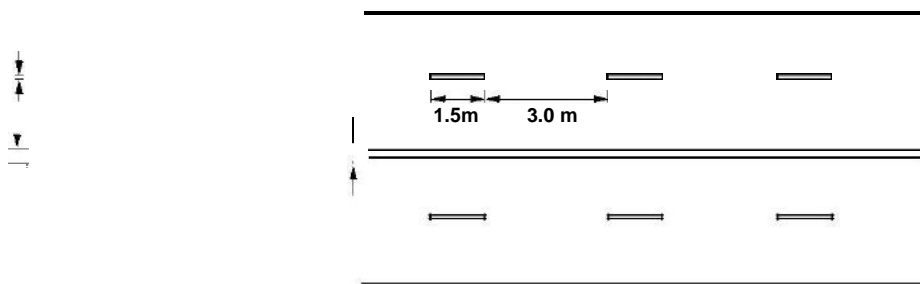

Figure 37:5: Lane marking for a four lane road with solid barrier line

Traffic lane lines

The subdivision of wide carriageways into separate lanes on either side of the carriage way helps the driver to go straight and also curbs the meandering tendency of the driver. At intersections, these traffic lane lines will eliminate confusion and facilitates turning movements. Thus traffic lane markings help in increasing the capacity of the road in addition ensuring more safety. The traffic lane lines are normally single broken lines of 100 mm width. Some examples are shown in figure 37:5 and figure 37:6.

No passing zones

No passing zones are established on summit curves, horizontal curves, and on two lane and three lane highways where overtaking maneuvers are prohibited because of low sight distance. It may be marked by a solid yellow line along the centre or a double yellow line. In the case of a double yellow line, the left hand element may be a solid barrier line, the right hand may be a either a broken line or a solid line. These solid lines are also called barrier lines. When a solid line is to the right of the broken line, the passing restriction shall apply only to the

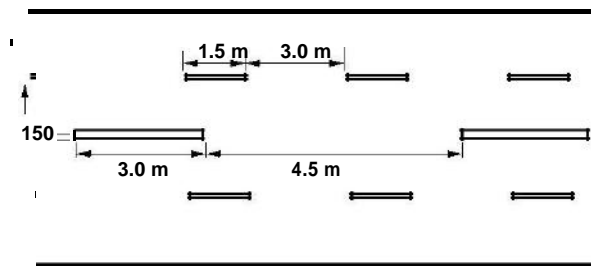
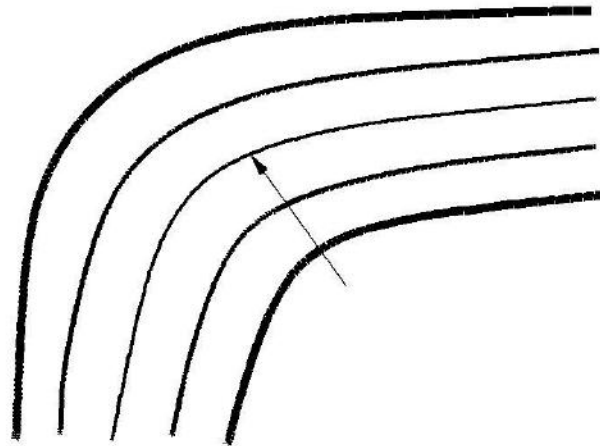

Figure 37:6: Traffic lane marking for a four lane road with broken centre line



Yellow single/double line

Figure 37:7: Barrier line marking for a four lane road

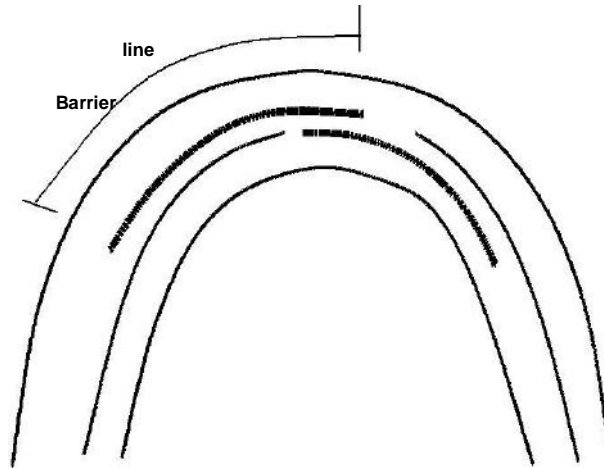

Figure 37:8: No passing zone marking at horizontal curves

Opposing traffic. Some typical examples are shown in figure 37:7 and figure 37:8. In the latter case, the no passing zone is staggered for each direction.

Warning lines

Warning lines warn the drivers about the obstruction approaches. They are marked on horizontal and vertical curves where the visibility is greater than prohibitory criteria specified for no overtaking zones. They are broken lines with 6 m length and 3 m gap. A minimum of seven line segments should be provided. A typical example is shown in figure 37:9

Edge lines

Edge lines indicate edges of rural roads which have no kerbs to delineate the limits up to which the driver can safely venture. They should be at least 150 mm from the actual edge of the pavement. They are painted in yellow or white.

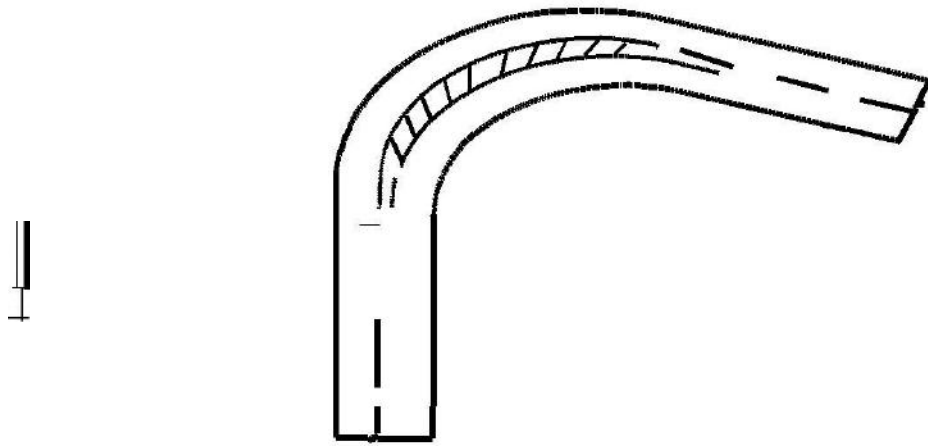

Figure 37:9: Warning line marking for a two lane road

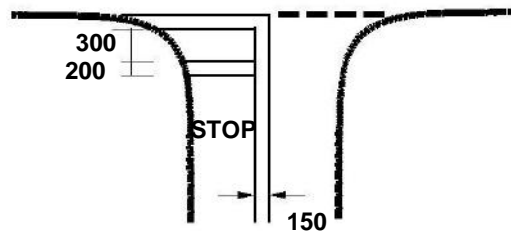

Figure 37:10: Stop line marking near an intersection

All the lines should be preferably light reflective, so that they will be visible during night also. Improved night visibility may also be obtained by the use of minute glass beads embedded in the pavement marking materials to produce a restore reflective surface.

Transverse markings

Transverse markings are marked across the direction of traffic. They are marked at intersections etc. The site conditions play a very important role. The type of road marking for a particular intersection depends on several variables such as speed characteristics of traffic, availability of space etc. Stop line markings, markings for pedestrian crossing, direction arrows, etc. are some of the markings on approaches to intersections.

Stop line

Stop line indicates the position beyond which the vehicles should not proceed when required to stop by control devices like signals or by traffic police. They should be placed either parallel to the intersecting roadway or at right angles to the direction of approaching vehicles. An example for a stop line marking is shown in figure 37:10.

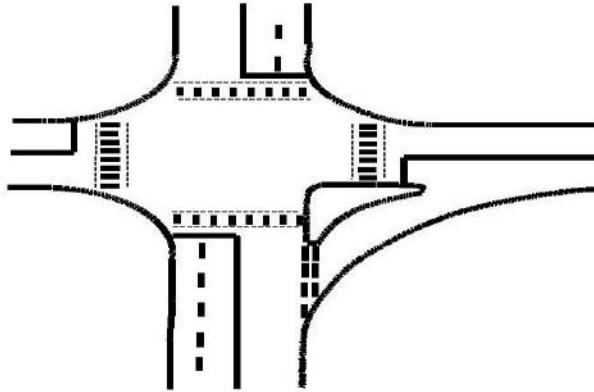

Figure 37:11: Pedestrian marking near an intersection

Pedestrian crossings

Pedestrian crossings are provided at places where the conflict between vehicular and pedestrian traffic is severe. The site should be selected that there is less inconvenience to the pedestrians and also the vehicles are not interrupted too much. At intersections, the pedestrian crossings should be preceded by a stop line at a distance of 2 to 3m for un signalized intersections and at a distance of one meter for signalized intersections. Most commonly used pattern for pedestrian crossing is Zebra crossing consisting of equally spaced white strips of 500 mm wide. A typical example of an intersection illustrating pedestrian crossings is shown in figure 37:11.

Directional arrows

In addition to the warning lines on approaching lanes, directional arrows should be used to guide the drivers in advance over the correct lane to be taken while approaching busy intersections. Because of the low angle at which the markings are viewed by the drivers, the arrows should be elongated in the direction of traffic for adequate visibility. The dimensions of these arrows are also very important. A typical example of a directional arrow is shown in figure 37:12.

Object marking

Physical obstructions in a carriageway like traffic island or obstructions near carriageway like signal posts, pier etc. cause serious hazard to the flow of traffic and should be adequately marked. They may be marked on the objects adjacent to the carriageway.

Objects within the carriageway

The obstructions within the carriageway such as traffic islands, raised medians, etc. may be marked by not less than alternate black and yellow stripes. The stripes should slope forward at an angle of 45 with respect to

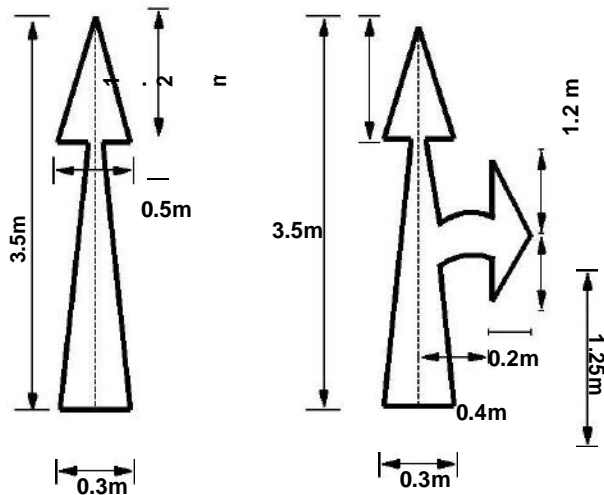

Figure 37:12: Directional arrow marking

the direction of traffic. These stripes shall be uniform and should not be less than 100 m wide so as to provide sufficient visibility.

Objects adjacent to carriageway

Sometimes objects adjacent to the carriageway may pose some obstructions to the flow of traffic. Objects such as subway piers and abutments, culvert head walls etc. are some examples for such obstructions. They should be marked with alternate black and white stripes at a forward angle of 45° with respect to the direction of traffic. Poles close to the carriageway should be painted in alternate black and white up to a height of 1.25 m above the road level. Other objects such as guard stones, drums, guard rails etc. where chances of vehicles hitting them are only when vehicle runs on the carriageway should be painted in solid white. Kerbs of all islands located in the line of traffic flow shall be painted with either alternating black and white stripes of 500 mm wide or red black and white stripes of same width. The object marking for central pier and side walls of an underpass is illustrated in figure 37:13.

Word messages

Information to guide, regulate, or warn the road user may also be conveyed by inscription of word message on road surface. Characters for word messages are usually capital letters. The legends should be as brief as possible and shall not consist of more than three words for any message. Word messages require more and important time to read and comprehend than other road markings. Therefore, only few and important ones are usually adopted. Some of the examples of word messages are STOP, SLOW, SCHOOL, RIGHT TURN ONLY etc. The character of a road message is also elongated so that driver looking at the road surface at a low angle can also read

them easily. The dimensioning of a typical alphabet is shown in figure 37:14.

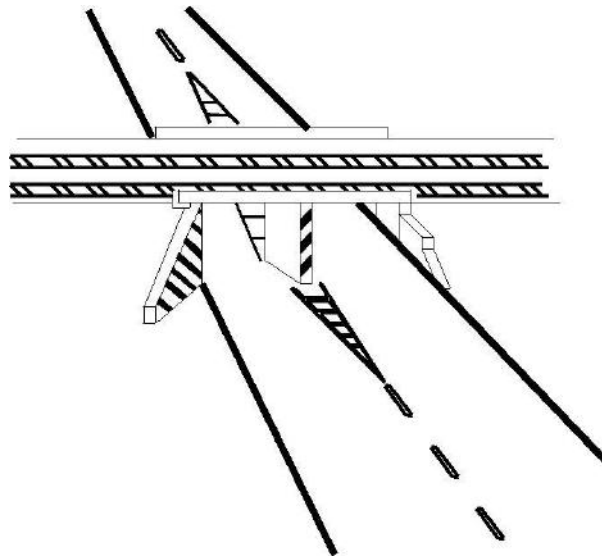

Figure 37:13: Marking for objects adjacent to the road way

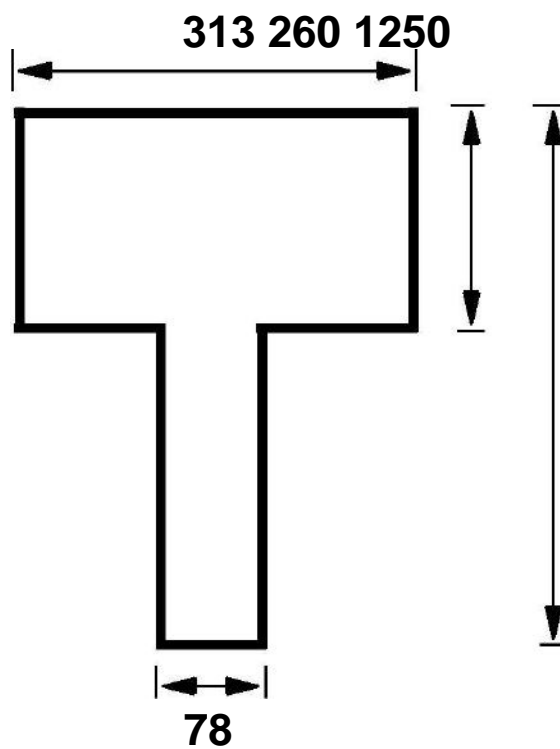

Figure 37:14: Typical dimension of the character T used in road marking

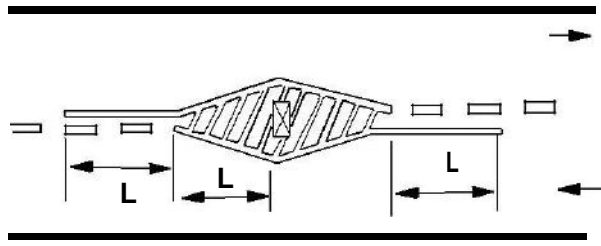

Figure 37:15: Approach marking for obstructions on the road way

Parking

The marking of the parking space limits on urban roads promotes more efficient use of the parking spaces and tends to prevent encroachment on places like bus stops, fire hydrant zones etc. where parking is undesirable. Such parking space limitations should be indicated with markings that are solid white lines 100 mm wide. Words TAXI, CARS, SCOOTERS etc. may also be written if the parking area is specific for any particular type of vehicle. To indicate parking restriction, kerb or carriage way marking of continuous yellow line 100 mm wide covering the top of kerb or carriageway close to it may be used.

Hazardous location

Wherever there is a change in the width of the road, or any hazardous location in the road, the driver should be warned about this situation with the help of suitable road markings. Road markings showing the width transition in the carriageway should be of 100 mm width. Converging lines shall be 150 mm wide and shall have a taper length of not less than twenty times the offset distance. Typical carriageway markings showing transition from wider to narrower sections and vice-versa is shown in figure 37:15. In the figure, the driver is warned about the position of the pier through proper road markings.

Parking

Parking is one of the major problems that is created by the increasing road traffic. It is an impact of transport development. The availability of less space in urban areas has increased the demand for parking space especially in areas like Central business district. This affects the mode choice also. This has a great economical impact.

Parking studies

Before taking any measures for the betterment of conditions, data regarding availability of parking space, extent of its usage and parking demand is essential. It is also required to estimate the parking fares also. Parking surveys are intended to provide all these information. Since the duration of parking varies with different vehicles, several statistics are used to access the parking need.

Parking statistics

Parking accumulation: It is defined as the number of vehicles parked at a given instant of time. Normally this is expressed by accumulation curve. Accumulation curve is the graph obtained by plotting the number of bays occupied with respect to time.

Parking volume: Parking volume is the total number of vehicles parked at a given duration of time. This does not account for repetition of vehicles. The actual volume of vehicles entered in the area is recorded.

Parking load: Parking load gives the area under the accumulation curve. It can also be obtained by simply multiplying the number of vehicles occupying the parking area at each time interval with the time interval. It is expressed as vehicle hours.

Average parking duration: It is the ratio of total vehicle hours to the number of vehicles parked.

$$\text{Parking duration} = \frac{\text{parking load}}{\text{Parking volume}}$$

Parking turnover: It is the ratio of number of vehicles parked in duration to the number of parking bays available.

$$\text{parking turnover} = \frac{\text{parking volume}}{\text{Number of bays available}}$$

This can be expressed as number of vehicles per day per time duration.

Parking volume:

Parking volume is the total number of vehicles parked at a given duration of time. This does not account for repetition of vehicles. The actual volume of vehicles entered in the area is recorded

Parking index: Parking index is also called occupancy or efficiency. It is defined as the ratio of number of bays occupied in time duration to the total space available. It gives an aggregate measure of how effectively the parking space is utilized. Parking index can be found out as follows

$$\text{parking index} = \frac{\text{parking load}}{\text{parking capacity}} \times 100 \quad (38.1)$$

To illustrate the various measures, consider a small example in figure 38:1, which shows the duration for which each of the bays are occupied (shaded portion). Now the accumulation graph can be plotted by simply noting the number of bays occupied at time interval of 15, 30, 45 etc. minutes is as shown in the figure.

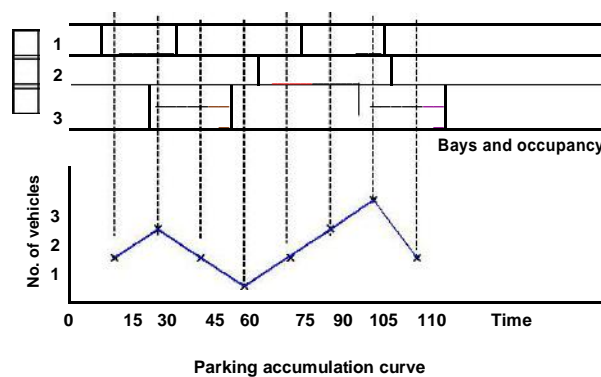

Figure 38:1: Parking bays and accumulation curve

Parking surveys

Parking surveys are conducted to collect the above said parking statistics. The most common parking surveys conducted are in-out survey, exceed period sampling and license plate method of survey.

2.2.4 In-out survey: In this survey, the occupancy count in the selected parking lot is taken at the beginning. Then the number of vehicles that enter the parking lot for a particular time interval is counted. The number of vehicles that leave the parking lot is also taken. The nil occupancy in the parking lot is also taken. Here the labor required is very less. Only one person may be enough. But we won't get any data regarding the time duration for which a particular vehicle used that parking lot. Parking duration and turnover is not obtained. Hence we cannot estimate the parking fare from this survey.

2.2.5 Fixed period sampling: This is almost similar to in-out survey. All vehicles are counted at the beginning of the survey. Then after a fixed time interval that may vary between 15 minutes to 1 hour, the count is again taken. Here there are chances of missing the number of vehicles that were parked for a short duration.

The marking of the parking space limits on urban roads promotes more efficient use of the parking spaces and tends to prevent encroachment on places like bus stops, fire hydrant zones etc. where parking is undesirable. Such parking space limitations should be indicated with markings that are solid white lines 100 mm wide. Words TAXI, CARS, SCOOTERS etc. may also be written if the parking area is specific for any particular type of vehicle. To indicate parking restriction, kerb or carriage way marking of continuous yellow line 100 mm wide covering the top of kerb or carriageway close to it may be used.

2.27 License plate method of survey: This results in the most accurate and realistic data. In this case of survey, every parking stall is monitored at a continuous interval of 15 minutes or so and the license plate number is noted down. This will give the data regarding the duration for which a particular vehicle was using the parking bay. This will help in calculating the fare because fare is estimated based on the duration for which the vehicle was parked. If the time interval is shorter, then there are less chances of missing short-term parkers. But this method is very labor intensive

5. Parking survey

- To identify parking patterns and occupancy rates
- Survey should cover
 - Study Area streets + streets within a buffer of 500 m on both sides
 - Both on-street parking + off-street public or semi-public parking
- Parking demand to be assessed and classified by vehicle type
- Parking fee structure

Ill effects of parking

Parking has some ill-effects like congestion, accidents, pollution, obstruction to re-lighting operations etc.

Congestion: Parking takes considerable street space leading to the lowering of the road capacity. Hence, speed will be reduced; journey time and delay will also subsequently increase. The operational count of the vehicle increases leading to great economical loss to the community.

Accidents: Careless maneuvering of parking and un parking leads to accidents which are referred to as parking accidents. Common type of parking accidents occur while driving out a car from the parking area, careless opening of the doors of parked cars, and while bringing in the vehicle to the parking lot for parking.

Environmental pollution: They also cause pollution to the environment because stopping and starting of vehicles while parking and un parking results in noise and fumes. They also affect the aesthetic beauty of the buildings because cars parked at every available space create a feeling that building rises from a plinth of cars.

Obstruction to relighting operations: Parked vehicles may obstruct the movement of relighting vehicles. Sometimes they block access to hydrants and access to buildings.

Parking requirements

There are some minimum parking requirements for different types of building. For residential plot area less than 300 sq.m require only community parking space. For residential plot area from 500 to 1000 sq.m, minimum one-fourth of the open area should be reserved for parking. Once it may require at least one space for every 70 sq.m as parking area. One parking space is enough for 10 seats in a restaurant where as theatres and cinema halls need to keep only 1 parking space for 20 seats. Thus, the parking requirements are different for different land use zones.

On street parking

On street parking means the vehicles are parked on the sides of the street itself. This will be usually controlled by government agencies itself. Common types of on-street parking are as listed below. This classification is based on the angle in which the vehicles are parked with respect to the road alignment. As per IRC the standard dimensions of a car is taken as 5 2.5 meters and that for a truck is 3.75 7.5 meters.

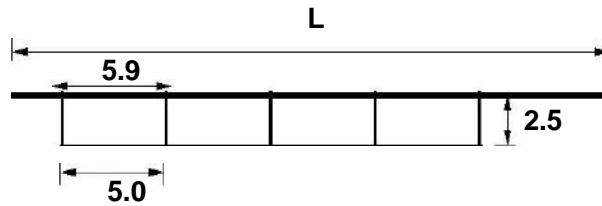

Figure 38:2: Illustration of parallel parking

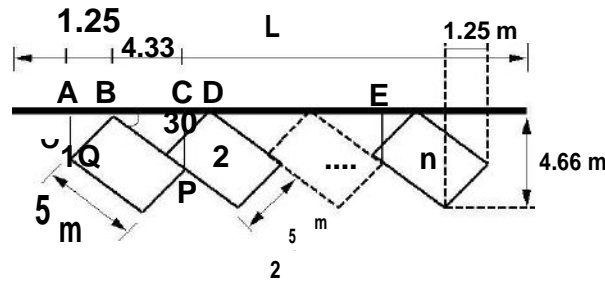

Figure 38:3: Illustration of 30 parking

Parallel parking: The vehicles are parked along the length of the road. Here there is no backward movement involved while parking or unpacking the vehicle. Hence, it is the safest parking from the accident perspective. However, it consumes the maximum curb length and therefore only a minimum number of vehicles can be parked for a given kerb length. This method of parking produces least obstruction to the on-going traffic on the road since least road width is used. Parallel parking of cars is shown in

30 parking: In thirty degree parking, the vehicles are parked at 30 with respect to the road alignment. In this case, more vehicles can be parked compared to parallel parking. Also there is better maneuver-ability. Delay caused to the traffic is also minimum in this type of parking. An example is shown in figure 38:3. From the figure,

$$\begin{aligned}
 AB &= OB \sin N 30 = 1:25; \\
 BC &= OP \cos N 30 = 4:33; \\
 BD &= DQ \cos N 60 = 5; \\
 CD &= BDBC = 5 \quad 4:33 = 0:67; \\
 AB + BC &= 1:25 + 4:33 = 5:58
 \end{aligned}$$

For N vehicles, $L = AC + (N-1)CE = 5.58 + (N-1)5 = 0.58 + 5N$

45 parking: As the angle of parking increases, more number of vehicles can be parked. Hence compared to parallel parking and thirty degree parking, more number of vehicles can be accommodated in this type of parking. From figure 38:4, length of parking space available for parking N number of vehicles in a given kerb is $L = 3.54 N + 1.77$

60 parking: The vehicles are parked at 60 to the direction of road. More number of vehicles can be accommodated in this parking type. From the figure 38:5, length available for parking N vehicles $= 2.89N + 2.16$.

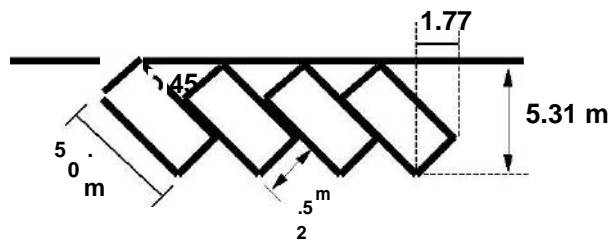

Figure 38:4: Illustration of 45 parking

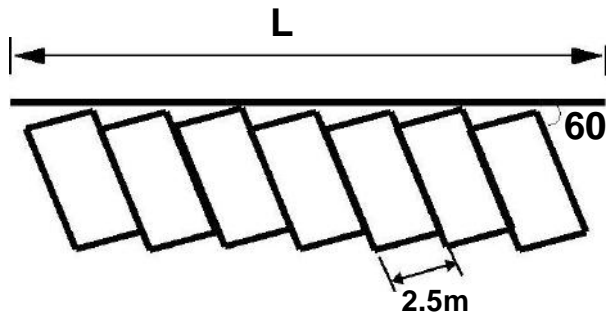

Figure 38:5: Illustration of 60 parking

Right angle parking: In right angle parking or 90 parking, the vehicles are parked perpendicular to the direction of the road. Although it consumes maximum width kerb length required is very little. In this type of parking, the vehicles need complex maneuvering and this may cause severe accidents. This arrangement causes obstruction to the road traffic particularly if the road width is less. However, it can accommodate maximum number of vehicles for a given kerb length. An example is shown in figure 38:6. Length available for parking N number of vehicles is $L = 2.5N$.

Off-street parking

In many urban centers, some areas are exclusively allotted for parking which will be at some distance away from the main stream of traffic. Such a parking is referred to as off-street parking. They may be operated by either public agencies or private firms. A typical layout of an off-street parking is shown in figure 38:7.

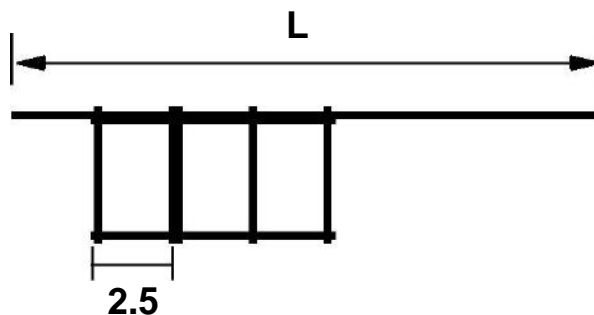

Figure 38:6: Illustration of 90 parking

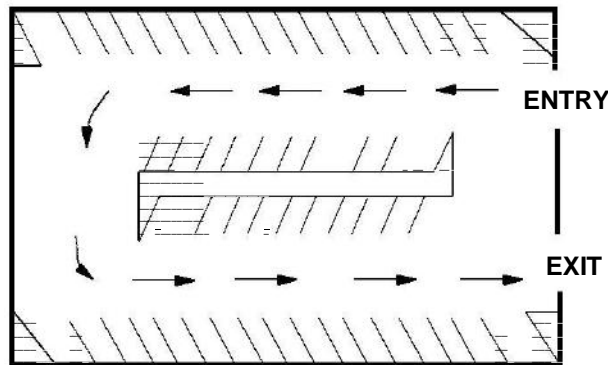

Figure 38:7: Illustration off-street parking

Example 1

From an in-out survey conducted for a parking area consisting of 40 bays, the initial count was found to be 25. Table gives the result of the survey. The number of vehicles coming in and out of the parking lot for a time interval of 5 minutes is as shown in the table 38:1. Find the accumulation, total parking load, average occupancy and efficiency of the parking lot.

Table 38:1: In-out survey data

Time	In	Out
5	3	2
10	2	4
15	4	2
20	5	4
25	7	3
30	8	2
35	2	7
40	4	2
45	6	4
50	4	1
55	3	3
60	2	5

Solution The solution is shown in table 38:2

Accumulation can be found out as initial count plus number of vehicles that entered the parking lot till that time minus the number of vehicles that just exited for that particular time interval. For the first time interval of 5 minutes, accumulation can be found out as $25+3-2 = 26$. It is being tabulated in column 4.

Occupancy or parking index is given by equation For the First time interval of Five minutes, parking index =

Table 38:2: In-out parking survey solution

Time (1)	In (2)	Out (3)	Accumulation (4)	Occupancy (5)	Parking load (6)
5	3	2	26	65	130
10	2	4	24	60	120
15	4	2	26	65	130
20	5	4	27	67.5	135
25	7	3	31	77.5	155
30	8	2	37	92.5	185
35	2	7	32	80	160
40	4	2	34	85	170
45	6	4	36	90	180
50	4	1	39	97.5	195
55	3	3	39	97.5	195
60	2	5	36	90	180
Total					1735

$(26/40) * 100 = 65\%$. The occupancy for the remaining time slot is similarly calculated and is tabulated in column 5.

Average occupancy is the average of the occupancy values for each time interval. Thus it is the average of all values given in column 5 and the value is 80.63%.

Parking load is tabulated in column 6. It is obtained by multiplying accumulation with the time interval. For the first time interval, parking load = $26 * 5 = 130$ vehicle minutes.

Total parking load is the summation of all the values in column 6 which is equal to 1735 vehicle minutes or 28.92 vehicle hours

Example 2

The parking survey data collected from a parking lot by license plate method is shown in the table 38:3 below. Find the average occupancy, average turnover, parking load, parking capacity and efficiency of the parking lot.

Solution See the following table for solution 38:4. Columns 1 to 5 are the input data. The parking status in every bay is coded first. If a vehicle occupies that bay for that time interval, then it has a code 1. This is shown in columns 6, 7, 8 and 9 of the table corresponding to the time intervals 15, 30, 45 and 60 seconds.

Turnover is computed as the number of vehicles present in that bay for that particular hour. For the first bay, it is counted as 3. Similarly, for the second bay, one vehicle is present throughout that hour and hence turnover is 1 itself. This is being tabulated in column 10 of the table. Average turnover =

$$\frac{\text{Sum of turn over}}{\text{Total number of bays}} = 2.25$$

Table 38:3: License plate parking survey data

Bay	Time			
	0-15	15-30	30-45	45-60
1	1456	9813	-	5678
2	1945	1945	1945	1945
3	3473	5463	5463	5463
4	3741	3741	9758	4825
5	1884	1884	-	7594
6	-	7357	-	7893
7	-	4895	4895	4895
8	8932	8932	8932	-
9	7653	7653	8998	4821
10	7321	-	2789	2789
11	1213	1213	3212	4778
12	5678	6678	7778	8888

Accumulation for a time interval is the total of number of vehicles in the bays 1 to 12 for that time interval. Accumulation for First time interval of 15 minutes = 1+1+1+1+1+0+0+1+1+1+1+1 = 10

Parking volume = Sum of the turnover in all the bays = 27 vehicles

Average duration is the average time for which the parking lot was used by the vehicles. It can be calculated as sum of the accumulation for each time interval time interval divided by the parking Volume = $\frac{(10+11+9+11) \cdot 15}{27} = 22.78$ minutes/vehicle.

Occupancy for that time interval is accumulation in that particular interval divided by total number of bays. For first time interval of 15 minutes, occupancy = $(10/12) \cdot 100 = 83\%$ Average occupancy is found out as the average of total number of vehicles occupying the bay for each time interval. It is expressed in Percentage. Average occupancy = $\frac{0.83+0.92+0.75+0.92}{4} \cdot 100 = 85.42\%$.

Parking capacity = number of bays * number of hours = 12 * 1 = 12 vehicle hours

Parking load = total number of vehicles accumulated at the end of each time interval time = 60 10.25 vehicle hours

Efficiency = $\frac{\text{Parking load}}{\text{Total number of bays}} = \frac{10.25}{12} = 85.42\%$.

UNIT4

INTERSECTION DESIGNS

UNIT4

INTERSECTION DESIGNS

Overview

Rotary intersections or roundabouts are special form of at-grade intersections laid out for the movement of traffic in one direction around a central traffic island. Essentially all the major conflicts at an intersection namely the collision between through and right-turn movements are converted into milder conflicts namely merging and diverging. The vehicles entering the rotary are gently forced to move in a clockwise direction in orderly fashion. They then weave out of the rotary to the desired direction. The benefits, design principles, capacity of rotary etc. will be discussed in this chapter.

Advantages and disadvantages of rotary

The key advantages of a rotary intersection are listed below:

- Traffic flow is regulated to only one direction of movement, thus eliminating severe conflicts between crossing movements.
- All the vehicles entering the rotary are gently forced to reduce the speed and continue to move at slower speed. Thus, none of the vehicles need to be stopped, unlike in a signalized intersection.
- Because of lower speed of negotiation and elimination of severe conflicts, accidents and their severity are much less in rotaries.
- Rotaries are self governing and do not need practically any control by police or traffic signals.
- They are ideally suited for moderate traffic, especially with irregular geometry, or intersections with more than three or four approaches.

Although rotaries have some distinct advantages, there are few specific limitations for rotaries which are listed below.

All the vehicles are forced to slow down and negotiate the intersection. Therefore, the cumulative delay will be much higher than channelized intersection.

Even when there is relatively low traffic, the vehicles are forced to reduce their speed.

Rotaries require large area of relatively flat land making them costly at urban areas.

The vehicles do not usually stop at a rotary. They accelerate and exit the rotary at relatively high speed. Therefore, they are not suitable when there are high pedestrian movements.

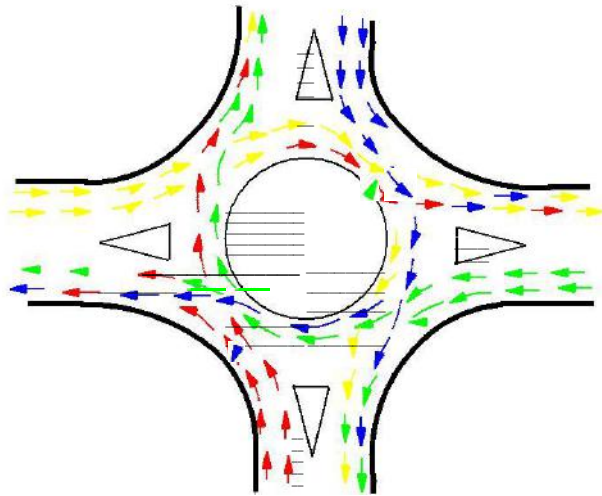

Figure 40:1: Traffic operations in a rotary

Guidelines for the selection of rotaries

Because of the above limitation, rotaries are not suitable for every location. There are few guidelines that help in deciding the suitability of a rotary. They are listed below.

- Rotaries are suitable when the traffic entering from all the four approaches are relatively equal.
- A total volume of about 3000 vehicles per hour can be considered as the upper limiting case and a volume of 500 vehicles per hour is the lower limit.
- A rotary is very beneficial when the proportion of the right-turn traffic is very high; typically if it is more than 30 percent.
- Rotaries are suitable when there are more than four approaches or if there is no separate lanes available for right-turn traffic. Rotaries are ideally suited if the intersection geometry is complex.

Traffic operations in a rotary

As noted earlier, the traffic operations at a rotary are three; diverging, merging and weaving. All the other conflicts are converted into these three less severe conflicts.

- ❖ **Diverging:** It is a traffic operation when the vehicles moving in one direction is separated into different streams according to their destinations.
- ❖ **Merging:** Merging is the opposite of diverging. Merging is referred to as the process of joining the traffic coming from different approaches and going to a common destination into a single stream.

- ❖ **Weaving:** Weaving is the combined movement of both merging and diverging movements in the same direction.

These movements are shown in figure 40:1. It can be observed that movements from each direction split into three; left, straight, and right turn.

Design elements

The design elements include design speed, radius at entry, exit and the central island, weaving length and width, entry and exit widths. In addition the capacity of the rotary can also be determined by using some empirical formula. A typical rotary and the important design elements are shown in figure 40:2

Design speed

All the vehicles are required to reduce their speed at a rotary. Therefore, the design speed of a rotary will be much lower than the roads leading to it. Although it is possible to design roundabout without much speed reduction, the geometry may lead to very large size incurring huge cost of construction. The normal practice is to keep the design speed as 30 and 40 kmph for urban and rural areas respectively.

Entry, exit and island radius

The radius at the entry depends on various factors like design speed, super-elevation, and coefficient of friction. The entry to the rotary is not straight, but a small curvature is introduced. This will force the driver to reduce the speed. The entry radius of about 20 and 25 metres is ideal for an urban and rural design respectively.

The exit radius should be higher than the entry radius and the radius of the rotary island so that the vehicles will discharge from the rotary at a higher rate. A general practice is to keep the exit radius as 1.5 to 2 times the entry radius. However, if pedestrian movement is higher at the exit approach, then the exit radius could be set as same as that of the entry radius.

The radius of the central island is governed by the design speed, and the radius of the entry curve. The radius of the central island, in practice, is given a slightly higher radius so that the movement of the traffic already in the rotary will have priority. The radius of the central island which is about 1.3 times that of the entry curve is adequate for all practical purposes

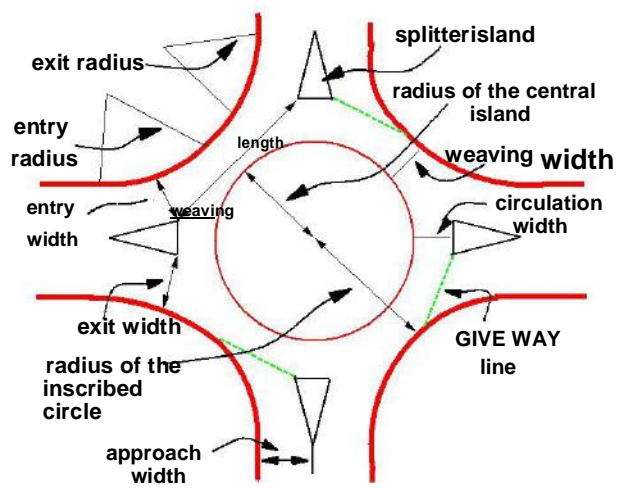

Figure 40:2: Design of a rotary



Figure 40:2(a): Design of a rotary

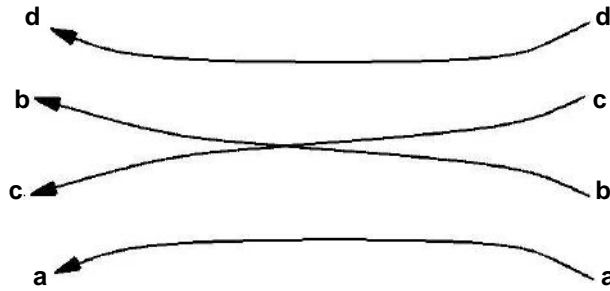

Figure 40:3: Weaving operation in a rotary

Width of the rotary

The entry width and exit width of the rotary is governed by the traffic entering and leaving the intersection and the width of the approaching road. The width of the carriageway at entry and exit will be lower than the width of the carriageway at the approaches to enable reduction of speed. IRC suggests that a two lane road of 7 m width should be kept as 7 m for urban roads and 6.5 m for rural roads. Further, a three lane road of 10.5 m is to be reduced to 7 m and 7.5 m respectively for urban and rural roads.

The width of the weaving section should be higher than the width at entry and exit. Normally this will be one lane more than the average entry and exit width. Thus weaving width is given as,

$$W_{\text{weaving}} = \frac{e_1 + e_2}{2} + 3.5\text{m} \quad (40.1)$$

where e_1 is the width of the carriageway at the entry and e_2 is the carriageway width at exit.

Weaving length determines how smoothly the traffic can merge and diverge. It is decided based on many factors such as weaving width, proportion of weaving traffic to the non-weaving traffic etc. This can be best achieved by making the ratio of weaving length to the weaving width very high. A ratio of 4 is the minimum value suggested by IRC. Very large weaving length is also dangerous, as it may encourage over-speeding.

Capacity

The capacity of rotary is determined by the capacity of each weaving section. Transportation road research lab (TRL) proposed the following empirical formula to find the capacity of the weaving section.

$$Q_w = \frac{280w[1 + \frac{e}{w}][1 - \frac{p}{3}]}{1 + \frac{w}{l}} \quad (40.2)$$

where e is the average entry and exit width, i.e, $\frac{(e_1 + e_2)}{2}$, w is the weaving width, l is the length of weaving, and

p is the proportion of weaving traffic to the non-weaving traffic. Figure 40:3 shows four types of movements at a weaving section, a and d are the non-weaving traffic and b and c are the weaving traffic. Therefore,

$$p = \frac{b + c}{a + b + c + d} \quad (40.3)$$

This capacity formula is valid only if the following conditions are satisfied.

1. Weaving width at the rotary is in between 6 and 18 meters.

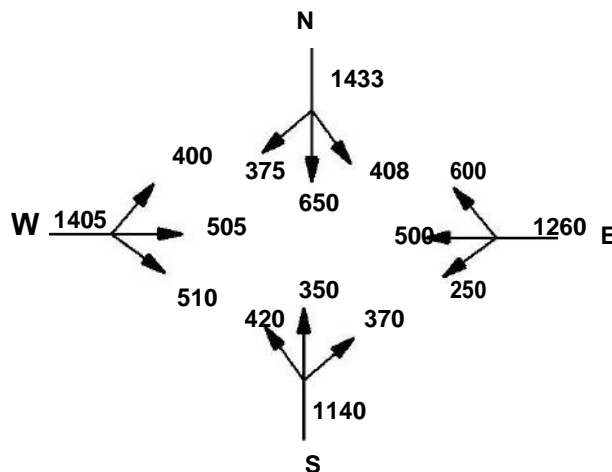

Figure 40:4: Traffic approaching the rotary

- ❖ The ratio of average width of the carriage way at entry and exit to the weaving width is in the range of 0.4 to 1.
- ❖ The ratio of weaving width to weaving length of the roundabout is in between 0.12 and 0.4.
- ❖ The proportion of weaving traffic to non-weaving traffic in the rotary is in the range of 0.4 and 1.
- ❖ The weaving length available at the intersection is in between 18 and 90 m.

Example

The width of a carriage way approaching an intersection is given as 15 m. The entry and exit width at the rotary is 10 m. The traffic approaching the intersection from the four sides is shown in the figure 40:4 below. Find the capacity of the rotary using the given data.

Solution

The traffic from the four approaches negotiating through the roundabout is illustrated in figure 40:5.

Weaving width is calculated as, $w = \left[\frac{e_1 + e_2}{2} \right] + 3 \cdot 5 = 13.5 \text{ m}$

Weaving length, l is calculated as $l = 4 \cdot w = 54 \text{ m}$

The proportion of weaving traffic to the non-weaving traffic in all the four approaches is found out first.

It is clear from equation that the highest proportion of weaving traffic to non-weaving traffic will give the minimum capacity. Let the proportion of weaving traffic to the non-weaving traffic in West-North direction be denoted as p_{WN} , in North-East direction as p_{NE} , in the East-South direction as p_{ES} , and finally in the South-West direction as p_{SW} .

The weaving traffic movements in the East-South direction is shown in figure 40:6. Then using equation, p_{ES}

$$p_{ES} = \frac{510 + 650 + 500 + 600}{510 + 650 + 500 + 600 + 250 + 375} = \frac{2260}{2885} = 0.783$$

$$p_{WN} = \frac{505 + 510 + 350 + 600}{505 + 510 + 350 + 600 + 400 + 370} = \frac{1965}{2735} = 0.718$$

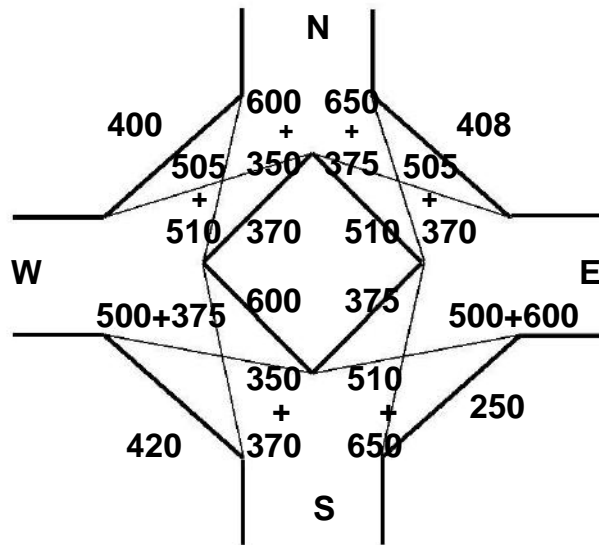

Figure 40:5: Traffic negotiating a rotary

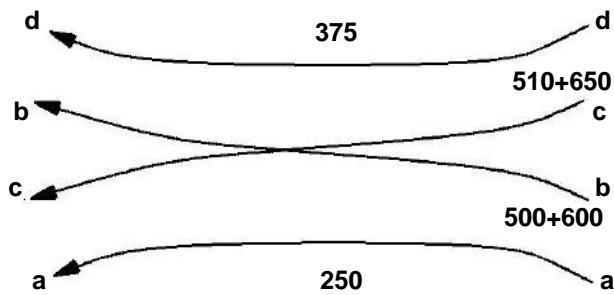

Figure 40:6: Traffic weaving in East-South direction

$$PNE = \frac{650+375+505+370}{650+375+505+370+510+408} = \frac{1900}{2818} = 0.674$$

$$PSW = \frac{350+370+500+375}{350+370+500+375+420+600} = \frac{1595}{2615} = 0.6099$$

Thus the proportion of weaving traffic to non-weaving traffic is highest in the East-South direction.

Therefore, the capacity of the rotary will be capacity of this weaving section. From equation,

$$Q_{ES} = \frac{280}{1 + \frac{13.5}{54}} \left[1 + \frac{10}{13.5} \right] \left[1 - \frac{0.783}{3} \right] = 2161.164 \text{ veh-hr} \quad (40.4)$$

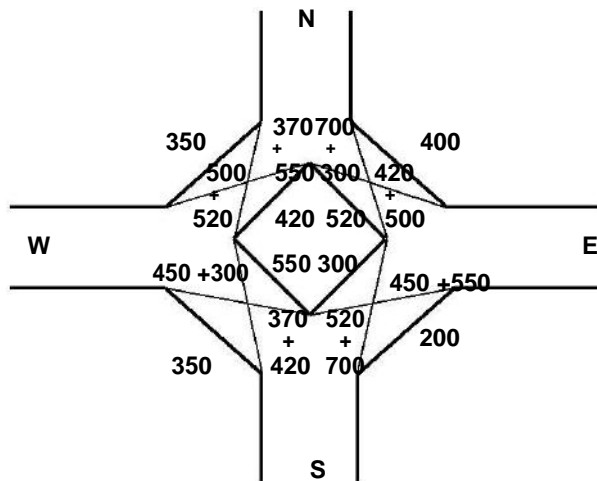

Figure 40:7: Traffic negotiating a rotary

Problems

The width of approaches for a rotary intersection is 12 m. The entry and exit width at the rotary is 10 m. Table below gives the traffic from the four approaches, traversing the intersection. Find the capacity of the rotary.

Approach	Left turn	Straight	Right turn
North	400	700	300
South	350	370	420
East	200	450	550
West	350	500	520

Solution

The traffic from the four approaches negotiating through the roundabout is illustrated in figure 40:7.

Weaving width is calculated as, $w = \left[\frac{e_1 + e_2}{2} \right] + 3:5 = 13.5 \text{ m}$

Weaving length can be calculated as, $l = 4 w = 54 \text{ m}$

The proportion of weaving traffic to the non-weaving traffic in all the four approaches is found out first.

It is clear from equation, that the highest proportion of weaving traffic to non-weaving traffic will give the minimum capacity. Let the proportion of weaving traffic to the non-weaving traffic in West-North direction be denoted as p_{WN} , in North-East direction as p_{NE} , in the East-South direction as p_{ES} , and finally

in the South-West direction as p_{SW} . Then using equation, $p_{ES} = \frac{450+550+700+520}{200+450+550+700+520+300} = \frac{2220}{2720} = 0.816$

$$p_{WN} = \frac{370+550+500+520}{350+370+550+500+520+420} = \frac{1920}{2510} = 0.69$$

$$p_{NE} = \frac{420+500+700+300}{520+400+420+500+700+300} = \frac{1920}{2840} = 0.676$$

$$p_{SW} = \frac{450+300+370+420}{550+450+400+370+420+350} = \frac{1540}{2540} = 0.630$$

UNIT5
HIGHWAY MATERIAL, CONSTRUCTION AND
MAINTENANCE

UNIT 5

HIGHWAY MATERIAL, CONSTRUCTION AND MAINTENANCE

Overview

A highway pavement is a structure consisting of superimposed layers of processed materials above the natural soil sub-grade, whose primary function is to distribute the applied vehicle loads to the sub-grade. The pavement structure should be able to provide a surface of acceptable riding quality, adequate skid resistance, favorable light reflecting characteristics, and low noise pollution. The ultimate aim is to ensure that the transmitted stresses due to wheel load are sufficiently reduced, so that they will not exceed bearing capacity of the sub-grade. Two types of pavements are generally recognized as serving this purpose, namely flexible pavements and rigid pavements. This chapter gives an overview of pavement types, layers, and their functions, and pavement failures. Improper design of pavements leads to early failure of pavements affecting the riding quality.

Requirements of a pavement

An ideal pavement should meet the following requirements:

- Sufficient thickness to distribute the wheel load stresses to a safe value on the sub-grad soil, structurally strong to withstand all types of stresses imposed upon it,
- Adequate coefficient of friction to prevent skidding of vehicles, Smooth surface to provide comfort to road users even at high speed, Produce least noise from moving vehicles,
- Dust proof surface so that traffic safety is not impaired by reducing visibility, Impervious surface, so that sub-grade soil is well protected, and
- Long design life with low maintenance cost.

Types of pavements

The pavements can be classified based on the structural performance into two, flexible pavements and rigid pavements. In flexible pavements, wheel loads are transferred by grain-to-grain contact of the aggregate through the granular structure. The flexible pavement, having less flexural strength, acts like a flexible sheet (e.g. bituminous road). On the contrary, in rigid pavements, wheel loads are transferred to sub-grade soil by flexural strength of the pavement and the pavement acts like a rigid plate (e.g. cement concrete roads). In addition to these, composite pavements are also available. A thin layer of flexible pavement over rigid pavement is an ideal pavement with most desirable characteristics. However, such pavements are rarely used in new construction because of

high cost and complex analysis required.

Failure of flexible pavements

The major flexible pavement failures are fatigue cracking, rutting, and thermal cracking. The fatigue cracking of flexible pavement is due to horizontal tensile strain at the bottom of the asphaltic concrete. The failure criterion relates allowable number of load repetitions to tensile strain and this relation can be determined in the laboratory fatigue test on asphaltic concrete specimens. Rutting occurs only on flexible pavements as indicated by permanent deformation or rut depth along wheel load path. Two design methods have been used to control rutting: one to limit the vertical compressive strain on the top of subgrade and other to limit rutting to a tolerable amount (12 mm normally). Thermal cracking includes both low-temperature cracking and thermal fatigue cracking.

Failure criteria of rigid pavements

Traditionally fatigue cracking has been considered as the major, or only criterion for rigid pavement design. The allowable number of load repetitions to cause fatigue cracking depends on the stress ratio between flexural tensile stress and concrete modulus of rupture. Of late, pumping is identified as an important failure criterion. Pumping is the ejection of soil slurry through the joints and cracks of cement concrete pavement, caused during the downward movement of slab under the heavy wheel loads. Other major types of distress in rigid pavements include faulting, spalling, and deterioration.

Pavements are a conglomeration of materials.

These materials, their associated properties, and their interactions determine the properties of the resultant pavement. Thus, a good understanding of these materials, how they are characterized, and how they perform is fundamental to understanding pavement. The materials which are used in the construction of highway are of intense interest to the highway engineer. This requires not only a thorough understanding of the soil and aggregate properties which affect pavement stability and durability, but also the binding materials which may be added to improve these pavement features.

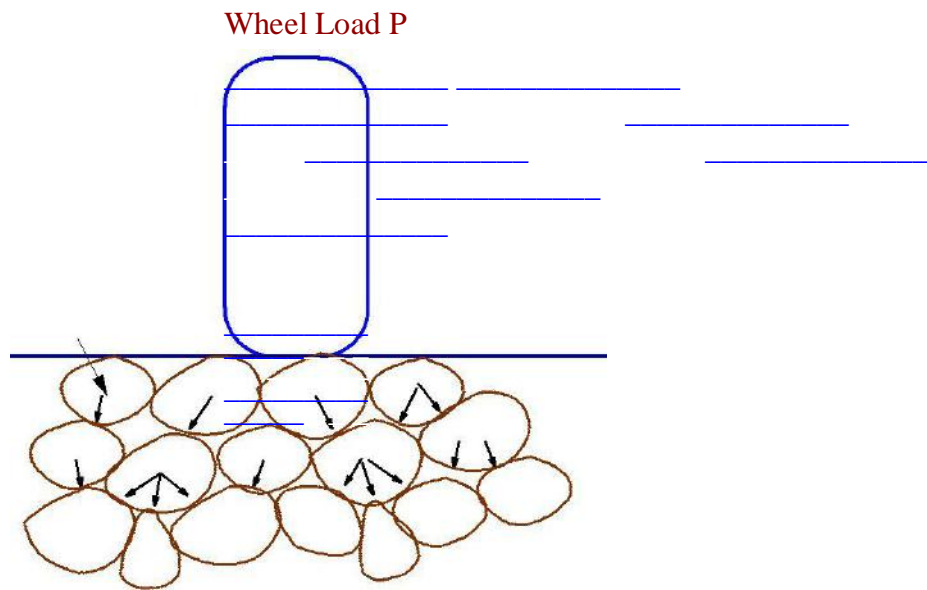

Figure 19:1: Load transfer in granular structure

Flexible pavements

Flexible pavements will transmit wheel load stresses to the lower layers by grain-to-grain transfer through the points of contact in the granular structure (see Figure 19:1). The wheel load acting on the pavement will be distributed to a wider area, and the stress decreases with the depth. Taking advantage of these stress distribution characteristic, flexible pavements normally has many layers. Hence, the design of flexible pavement uses the concept of layered system. Based on this, flexible pavement may be constructed in a number of layers and the top layer has to be of best quality to sustain maximum compressive stress, in addition to wear and tear. The lower layers will experience lesser magnitude of stress and low quality material can be used. Flexible pavements are constructed using bituminous materials. These can be either in the form of surface treatments (such as bituminous surface treatments generally found on low volume roads) or, asphalt concrete surface courses (generally used on high volume roads such as national highways). Flexible pavement layers reflect the deformation of the lower layers on to the surface layer (e.g., if there is any undulation in sub-grade then it will be transferred to the surface layer). In the case of flexible pavement, the design is based on overall performance of flexible pavement, and the stresses produced should be kept well below the allowable stresses of each pavement layer.

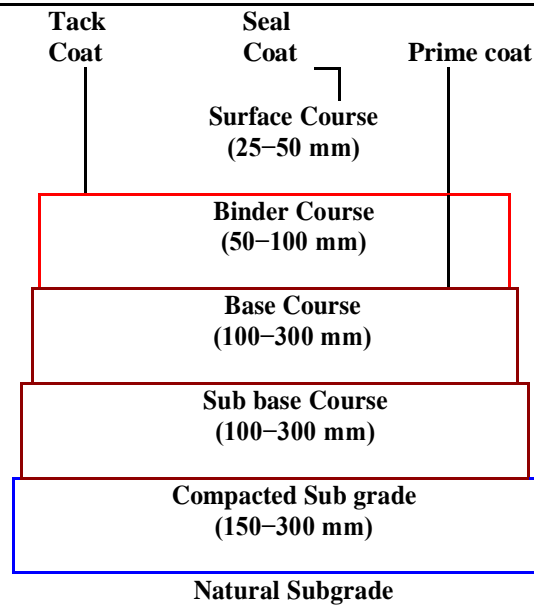

Figure 19:2: Typical cross section of a flexible pavement

Types of Flexible Pavements

The following types of construction have been used in flexible pavement:

- Conventional layered flexible pavement, full - depth asphalt pavement, and
- Contained rock asphalt mat (CRAM).

Conventional flexible pavements are layered systems with high quality expensive materials are placed in the top where stresses are high, and low quality cheap materials are placed in lower layers.

Full - depth asphalt pavements are constructed by placing bituminous layers directly on the soil sub-grade. This is more suitable when there is high traffic and local materials are not available.

Contained rock asphalt mats are constructed by placing dense/open graded aggregate layers in between two asphalt layers. Modified dense graded asphalt concrete is placed above the sub-grade will significantly reduce the vertical compressive strain on soil sub-grade and protect from surface water.

Typical layers of a flexible pavement

Typical layers of a conventional flexible pavement includes seal coat, surface course, tack coat,

binder course, prime coat, base course, sub-base course, compacted sub-grade, and natural sub-grade (Figure 19:2).

Seal Coat: Seal coat is a thin surface treatment used to water-proof the surface and to provide skid resistance.

Tack Coat: Tack coat is a very light application of asphalt, usually asphalt emulsion diluted with water. It provides proper bonding between two layer of binder course and must be thin, uniformly cover the entire surface, and set very fast.

Prime Coat: Prime coat is an application of low viscous cutback bitumen to an absorbent surface like granular bases on which binder layer is placed. It provides bonding between two layers. Unlike tack coat, prime coat penetrates into the layer below, plugs the voids, and forms a water tight surface.

Surface course

Surface course is the layer directly in contact with traffic loads and generally contains superior quality materials. They are usually constructed with dense graded asphalt concrete (AC). The functions and requirements of this layer are:

It provides characteristics such as friction, smoothness, drainage, etc. Also it will prevent the entrance of excessive quantities of surface water into the underlying base, sub-base and sub-grade,

It must be tough to resist the distortion under traffic and provide a smooth and skid- resistant riding surface,

It must be water proof to protect the entire base and sub-grade from the weakening effect of water.

Binder course

This layer provides the bulk of the asphalt concrete structure. Its chief purpose is to distribute load to the base course. The binder course generally consists of aggregates having less asphalt and doesn't require quality as high as the surface course, so replacing a part of the surface course by the binder course results in more economical design.

Base course

The base course is the layer of material immediately beneath the surface of binder course and it

provides additional load distribution and contributes to the sub-surface drainage. It may be composed of crushed stone, crushed slag, and other untreated or stabilized materials.

Sub-Base course

The sub-base course is the layer of material beneath the base course and the primary functions are to provide structural support, improve drainage, and reduce the intrusion from the sub-grade in the pavement structure. If the base course is open graded, then the sub-base course with more can serve as a leer between sub-grade and the base course. A sub-base course is not always needed or used. For example, a pavement constructed over a high quality, sub-grade may not need the additional features by a sub-base course. In such situations, sub-base course may not be provided.

Sub-grade

The top soil or sub-grade is a layer of natural soil prepared to receive the stresses from the layers above. It is essential that at no time soil sub-grade is overstressed. It should be compacted to the desirable density, near the optimum moisture content.

Failure of flexible pavements

The major flexible pavement failures are fatigue cracking, rutting, and thermal cracking. The fatigue cracking of flexible pavement is due to horizontal tensile strain at the bottom of the asphaltic concrete. The failure criterion relates allowable number of load repetitions to tensile strain and this relation can be determined in the laboratory fatigue test on asphaltic concrete specimens. Rutting occurs only on flexible pavements as indicated by permanent deformation or rut depth along wheel load path. Two design methods have been used to control rutting: one to limit the vertical compressive strain on the top of sub grade and other to limit rutting to a tolerable amount (12 mm normally). Thermal cracking includes both low-temperature cracking and thermal fatigue cracking. The major flexible pavement failures are fatigue cracking, rutting, and thermal cracking. The fatigue cracking of flexible pavement is due to horizontal tensile strain at the bottom of the asphaltic concrete. The failure criterion relates allowable number of load repetitions to tensile strain and this relation can be determined in the laboratory fatigue test on asphaltic concrete specimens. Rutting occurs only on flexible pavements as indicated by permanent deformation or rut depth along wheel load path. Two design methods have been used to control rutting: one to limit the vertical

compressive strain on the top of subgrade and other to limit rutting to a tolerable amount (12 mm normally). Thermal cracking includes both low-temperature cracking and thermal fatigue cracking.

Requirements of a pavement

- An ideal pavement should meet the following requirements:
- Sufficient thickness to distribute the wheel load stresses to a safe value on the sub-grade soil,
- Structurally strong to withstand all types of stresses imposed upon it,
- Adequate coefficient of friction to prevent skidding of vehicles,
- Smooth surface to provide comfort to road users even at high speed,
- Produce least noise from moving vehicles,
- Dust proof surface so that traffic safety is not impaired by reducing visibility,
- Impervious surface, so that sub-grade soil is well protected, and
- Long design life with low maintenance cost.

Types of pavements

The pavements can be classified based on the structural performance into two, flexible pavements and rigid pavements. In flexible pavements, wheel loads are transferred by grain-to-grain contact of the aggregate through the granular structure. The flexible pavement, having less flexural strength, acts like a flexible sheet (e.g. bituminous road). On the contrary, in rigid pavements, wheel loads are transferred to sub-grade soil by flexural strength of the pavement and the pavement acts like a rigid plate (e.g. cement concrete roads). In addition to these, composite pavements are also available. A thin layer of flexible pavement over rigid pavement is an ideal pavement with most desirable characteristics. However, such pavements are rarely used in new construction because of high cost and complex analysis required

As you see here Indian Roads Congress guidelines for design of flexible pavements are given in IRC: 37. This is the number of the guidelines that is given by Indian Roads Congress, 2001 indicates the year in which the latest revision has been given. So we are going to discuss about the provisions of Indian Roads Congress 37: 2001. These guidelines are result of research work carried out by various institutions in India on the basis of performance data that is collected on different pavement sections in India and this version of IRC guideline 37 for designing flexible pavements is considered to be more rational compared to its previous version which was issued in 1984.

Rigid pavements have sufficient flexural strength to transmit the wheel load stresses to a wider area below. A typical cross section of the rigid pavement is shown in Figure 19:3. Compared to flexible pavement, rigid pavements are placed either directly on the prepared sub-grade or on a single layer of granular or stabilized material. Since there is only one layer of material between the concrete and the sub-grade, this layer can be called as base or sub-base course

Typical layers of a flexible pavement

Typical layers of a conventional flexible pavement includes seal coat, surface course, tack coat, binder course, prime coat, base course, sub-base course, compacted sub-grade, and natural sub-grade

Seal Coat:

Seal coat is a thin surface treatment used to water-proof the surface and to provide skid resistance.

Tack Coat:

Tack coat is a very light application of asphalt, usually asphalt emulsion diluted with water. It provides proper bonding between two layer of binder course and must be thin, uniformly cover the entire surface, and set very fast.

Prime Coat:

Prime coat is an application of low viscous cutback bitumen to an absorbent surface like granular bases on which binder layer is placed. It provides bonding between two layers. Unlike tack coat, prime coat penetrates into the layer below, plugs the voids, and forms a water tight surface.

Surface course

Surface course is the layer directly in contact with traffic loads and generally contains superior quality materials. They are usually constructed with dense graded asphalt concrete (AC).

The functions and requirements of this layer are:

It provides characteristics such as friction, smoothness, drainage, etc. Also it will prevent the entrance of excessive quantities of surface water into the underlying base, sub-base and sub-grade, It must be tough to resist the distortion under traffic and provide a smooth and skid- resistant riding surface.

It must be water proof to protect the entire base and sub-grade from the weakening effect of water.

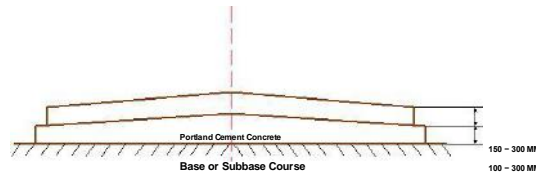

Figure 19:3: Typical Cross section of Rigid pavement

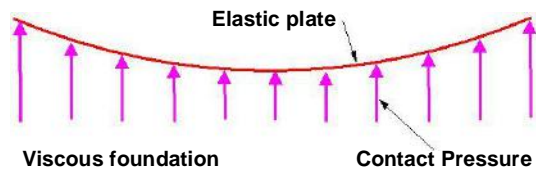

Figure 19:4: Elastic plate resting on Viscous foundation

Rigid pavements

Rigid pavements have sufficient flexural strength to transmit the wheel load stresses to a wider area below. A typical cross section of the rigid pavement is shown in Figure 19:3. Compared to flexible pavement, rigid pavements are placed either directly on the prepared sub-grade or on a single layer of granular or stabilized material. Since there is only one layer of material between the concrete and the sub-grade, this layer can be called as base or sub-base course.

In rigid pavement, load is distributed by the slab action, and the pavement behaves like an elastic plate resting on a viscous medium (Figure 19:4). Rigid pavements are constructed by Portland cement concrete (PCC) and should be analyzed by plate theory instead of layer theory, assuming an elastic plate resting on viscous foundation. Plate theory is a simplified version of layer theory that assumes the concrete slab as a medium thick plate which is plane before loading and to remain plane after loading. Bending of the slab due to wheel load and temperature variation and the resulting tensile and flexural stress.

Types of Rigid Pavements

Rigid pavements can be classified into four types:

1. Jointed plain concrete pavement (JPCP),
2. Jointed reinforced concrete pavement (JRCP),
3. Continuous reinforced concrete pavement (CRCP), and Pre-stressed concrete pavement

Jointed Plain Concrete Pavement: are plain cement concrete pavements constructed with closely spaced contraction joints. Dowel bars or aggregate interlocks are normally used for load transfer across joints. They normally has a joint spacing of 5 to 10m.

Jointed Reinforced Concrete Pavement: Although reinforcements do not improve the structural capacity significantly, they can drastically increase the joint spacing to 10 to 30m. Dowel bars are required for load transfer. Reinforcement's help to keep the slab together even after cracks.

Continuous Reinforced Concrete Pavement: Complete elimination of joints are achieved by reinforcement.

Binder course

This layer provides the bulk of the asphalt concrete structure. It's chief purpose is to distribute load to the base course The binder course generally consists of aggregates having less asphalt and doesn't require quality as high as the surface course, so replacing a part of the surface course by the binder course results in more economical design.

Base course

The base course is the layer of material immediately beneath the surface of binder course and it provides additional load distribution and contributes to the sub-surface drainage It may be composed of crushed stone, crushed slag, and other untreated or stabilized materials.

Production of Bitumen

Bitumen is the residue or by-product when the crude petroleum is re need. A wide variety of re nary processes, such as the straight distillation process, solvent extraction process etc. may be used to produce bitumen of different consistency and other desirable properties. Depending on the sources and characteristics of the crude oils and on the properties of bitumen required, more than one processing method may be employed.

Failure criteria of rigid pavements

Traditionally fatigue cracking has been considered as the major or only criterion for rigid pavement design. The allowable number of load repetitions to cause fatigue cracking depends on the stress ratio between flexural tensile stress and concrete modulus of rupture. Of late, pumping is identified as an important failure criterion. Pumping is the ejection of soil slurry through the joints and cracks of cement concrete pavement, caused during the downward movement of slab under the heavy wheel loads. Other major types of distress in rigid pavements include faulting, spalling, and deterioration.

Bituminous materials or asphalts are extensively used for roadway construction, primarily because of their excellent binding characteristics and water proofing properties and relatively low cost. Bituminous materials consist of bitumen which is a black or dark colored solid or viscous cementitious substance consisting chiefly of high molecular weight hydrocarbons derived from distillation of petroleum or natural asphalt, has adhesive properties, and is soluble in carbon disulphide. Tars are residues from the destructive distillation of organic substances such as coal, wood, or petroleum and are temperature sensitive than bitumen. Bitumen will be dissolved in petroleum oils whereas unlike tar.

Vacuum steam distillation of petroleum oils

In the vacuum-steam distillation process the crude oil is heated and is introduced into a large cylindrical still. Steam is introduced into the still to aid in the vaporization of the more volatile constituents of the petroleum and to minimize decomposition of the distillates and residues. The volatile constituents are collected, condensed, and the various fractions stored for further refining, if needed. The residues from this distillation are then fed into a vacuum distillation unit, where residue pressure and steam will further separate out heavier gas oils. The bottom fraction from this unit is the vacuum-steam-refined asphalt cement. The consistency of asphalt cement from this process can be controlled by the amount of heavy gas oil removed. Normally, asphalt produced by this process is softer. As the asphalt cools down to room temperature, it becomes a semi solid viscous material.

Different forms of bitumen

Cutback bitumen

Normal practice is to heat bitumen to reduce its viscosity. In some situations preference is given to

use liquid binders such as cutback bitumen. In cutback bitumen suitable solvent is used to lower the viscosity of the Bitumen. From the environmental point of view also cutback bitumen is preferred. The solvent from the bituminous material will evaporate and the bitumen will bind the aggregate. Cutback bitumen is used for cold weather bituminous road construction and maintenance. The distillates used for preparation of cutback bitumen are naphtha, kerosene, diesel oil, and furnace oil. There are different types of cutback bitumen like rapid curing (RC), medium curing (MC), and slow curing (SC). RC is recommended for surface dressing and patchwork. MC is recommended for premix with less quantity of aggregate. SC is used for premix with appreciable quantity of aggregate.

Bitumen Emulsion

Bitumen emulsion is a liquid product in which bitumen is suspended in a newly divided condition in an aqueous medium and stabilized by suitable material. Normally cationic type emulsions are used in India. The bitumen content in the emulsion is around 60% and the remaining is water. When the emulsion is applied on the road it breaks down resulting in release of water and the mix starts to set. The time of setting depends upon the grade of bitumen. The viscosity of bituminous emulsions can be measured as per IS: 8887-1995. Three types of bituminous emulsions are available, which are Rapid setting (RS), Medium setting (MS), and Slow setting (SC). Bitumen emulsions are ideal binders for hill road construction. Where heating of bitumen or aggregates are difficult. Rapid setting emulsions are used for surface dressing work. Medium setting emulsions are preferred for premix jobs and patch repairs work. Slow setting emulsions are preferred in rainy season.

Bituminous primers

In bituminous primer the distillate is absorbed by the road surface on which it is spread. The absorption therefore depends on the porosity of the surface. Bitumen primers are useful on the stabilized surfaces and water bound macadam base courses. Bituminous primers are generally prepared on road sites by mixing penetration bitumen with petroleum distillate. The residues from this distillation are then fed into a vacuum distillation unit, where residue pressure and steam will further separate out heavier gas oils. The bottom fraction from this unit is the vacuum-steam-rene asphalt cement. The consistency of asphalt cement from this process can be controlled by the amount of heavy gas oil removed. Normally, asphalt produced by this process is softer. As the asphalt cools down to room temperature, it becomes a semi solid viscous material.

Modified Bitumen

Certain additives or blend of additives called as bitumen modifiers can improve properties of Bitumen and bituminous mixes. Bitumen treated with these modifiers is known as modified bitumen. Polymer modified bitumen (PMB)/ crumb rubber modified bitumen (CRMB) should be used only in wearing course depending upon the requirements of extreme climatic variations. The detailed specifications for modified bitumen have been issued by IRC: SP: 53-1999. It must be noted that the performance of PMB and CRMB is dependent on strict control on temperature during construction. The advantages of using modified bitumen are as follows

- Lower susceptibility to daily and seasonal temperature variations
- Higher resistance to deformation at high pavement temperature
- Better age resistance properties
- Higher fatigue life for mixes
- Better adhesion between aggregates and binder
- Prevention of cracking and reflective cracking

Requirements of Bitumen

The desirable properties of bitumen depend on the mix type and construction. In general, Bitumen should possess following desirable properties.

The bitumen should not be highly temperature susceptible: during the hottest weather the mix should not become too soft or unstable, and during cold weather the mix should not become too brittle causing cracks.

The viscosity of the bitumen at the time of mixing and compaction should be adequate. This can be achieved by use of cutbacks or emulsions of suitable grades or by heating the bitumen and aggregates prior to mixing.

There should be adequate affinity and adhesion between the bitumen and aggregates used in the mix.

Tests on bitumen

There are a number of tests to assess the properties of bituminous materials. The following tests are usually conducted to evaluate different properties of bituminous materials.

Penetration test

Ductility test

Softening point test

Specific gravity test

Viscosity test

Flash and Fire point test

Float test

Water content test

Loss on heating test

Penetration test

It measures the hardness or softness of bitumen by measuring the depth in tenths of a millimeter to which a standard loaded needle will penetrate vertically in 5 seconds. BIS had standardized the equipment and test procedure. The penetrometer consists of a needle assembly with a total weight of 100g and a device for releasing and locking in any position. The bitumen is softened to a pouring consistency, stirred thoroughly and poured into containers at a depth at least 15 mm in excess of the expected penetration. The test should be conducted at a specified temperature of 25° C. It may be noted that penetration value is largely influenced by any inaccuracy with regards to pouring temperature, size of the needle, weight placed on the needle and the test temperature. A grade of 40/50 bitumen means the penetration value is in the range 40 to 50 at standard test conditions. In hot climates, a lower penetration grade is preferred. The Figure 23.4.1 shows a schematic Penetration Test setup.

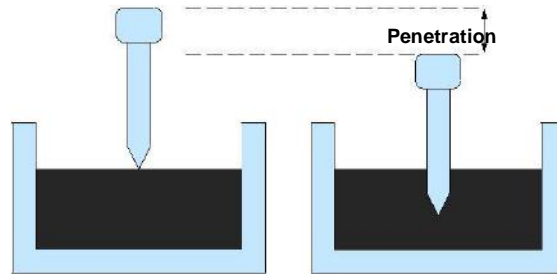

Figure 23:1: Penetration Test Setup

Ductility test

Ductility is the property of bitumen that permits it to undergo great deformation or elongation. Ductility is defined as the distance in cm, to which a standard sample or briquette of the material will be elongated without breaking. Dimension of the briquette thus formed is exactly 1 cm square. The bitumen sample is heated and poured in the mould assembly placed on a plate. These samples with moulds are cooled in the air and then in water bath at 27° C temperature. The excess bitumen is cut and the surface is leveled using a hot knife. Then the mould with assembly containing sample is kept in water bath of the ductility machine for about 90 minutes. The sides of the moulds are removed, the clips are hooked on the machine and the machine is operated. The distance up to the point of breaking of thread is the ductility value which is reported in cm. The ductility value gets affected by factors such as pouring temperature, test temperature, rate of pulling etc. A minimum ductility value of 75 cm has been specified by the BIS. Figure 23.4.2 shows ductility moulds to be filled with bitumen.

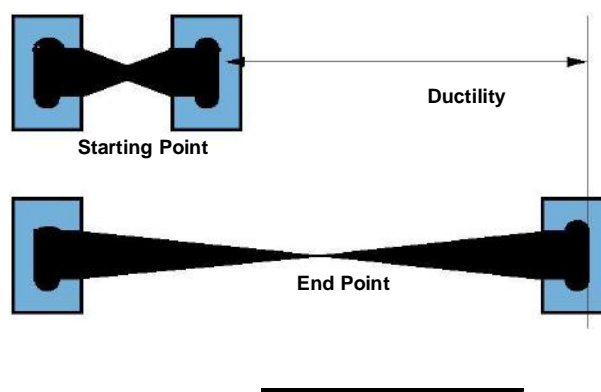

Figure 23:2: Ductility Test

Softening point test

Softening point denotes the temperature at which the bitumen attains a particular degree of

softening under the specifications of test. The test is conducted by using Ring and Ball apparatus. A brass ring containing test sample of bitumen is suspended in liquid like water or glycerin at a given temperature. A steel ball is placed upon the bitumen sample and the liquid medium is heated at a rate of 5° C per minute. Temperature is noted when the softened bitumen touches the metal plate which is at a specified distance below. Generally, higher

Softening point indicates lower temperature susceptibility and is preferred in hot climates. Figure 23.4.3 shows Softening Point test setup.

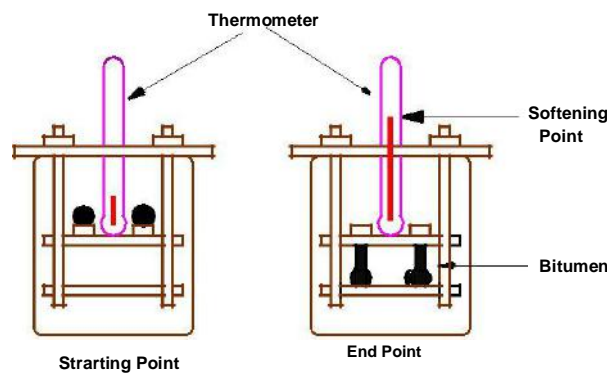

Figure 23:3: Softening Point Test Setup

Specific gravity test

In paving jobs, to classify a binder, density property is of great use. In most cases bitumen is weighed, but when used with aggregates, the bitumen is converted to volume using density values. The density of bitumen is greatly influenced by its chemical composition. Increase in aromatic type mineral impurities cause an increase in specific gravity.

The specific gravity of bitumen is defined as the ratio of mass of given volume of bitumen of known content to the mass of equal volume of water at 27° C. The specific gravity can be measured using either pycnometer or preparing a cube specimen of bitumen in semi solid or solid state. The specific gravity of bitumen varies from 0.97 to 1.02.

Viscosity test

Viscosity denotes the fluid property of bituminous material and it is a measure of resistance to flow. At the application temperature, this characteristic greatly influences the strength of resulting paving

mixes. Low or high viscosity during compaction or mixing has been observed to result in lower stability values. At high viscosity, it resists the compactive effort and thereby resulting mix is heterogeneous, hence low stability values. And at low viscosity instead of providing a uniform film over aggregates, it will lubricate the aggregate particles. Orifice type viscometers are used to indirectly measure the viscosity of liquid binders like cutbacks and emulsions. The viscosity expressed in seconds is the time taken by the 50 ml bitumen material to pass through the orifice of a cup, under standard test conditions and specified temperature. Viscosity of a cutback can be measured with either 4.0 mm orifice at 25° C or 10 mm orifice at 25 or 40° C.

Flash and fire point test

At high temperatures depending upon the grades of bitumen materials leave out volatiles. And these volatiles catch fire which is very hazardous and therefore it is essential to qualify this temperature for each bitumen grade. BIS defined the flash point as the temperature at which the vapor of bitumen momentarily catches

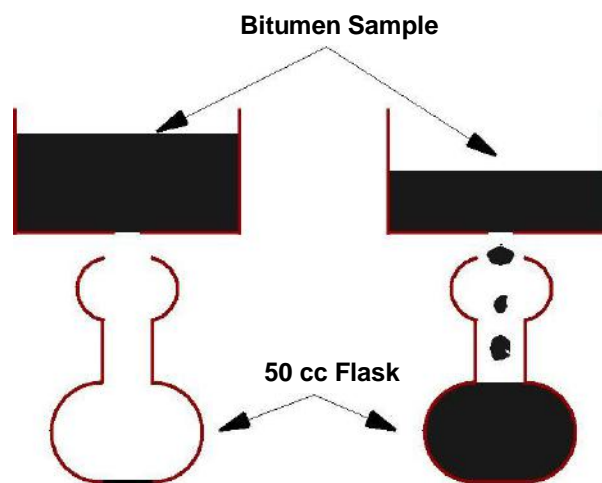

Figure 23:4: Viscosity Test

in the form of ash under specified test conditions. The fire point is defined as the lowest temperature under specified test conditions at which the bituminous material gets ignited and burns.

Float test

Normally the consistency of bituminous material can be measured either by penetration test or viscosity test. But for certain range of consistencies, these tests are not applicable and Float test is used. The apparatus consists of an aluminum float and a brass collar filled with bitumen to be tested.

The specimen in the mould is cooled to a temperature of 5°C and screwed in to oat. The total test assembly is floated in the water bath at 50°C and the time required for water to pass its way through the specimen plug is noted in seconds and is expressed as the oat value.

Water content test

It is desirable that the bitumen contains minimum water content to prevent foaming of the bitumen when it is heated above the boiling point of water. The water in bitumen is determined by mixing known weight of specimen in a pure petroleum distillate free from water, heating and distilling of the water. The weight of the water condensed and collected is expressed as percentage by weight of the original sample. The allowable maximum water content should not be more than 0.2% by weight.

Loss on heating test

When the bitumen is heated it loses the volatility and gets hardened. About 50gm of the sample is weighed and heated to a temperature of 163⁰C for 5hours in a specified oven designed for this test. The sample specimen is weighed again after the heating period and loss in weight is expressed as percentage by weight of the original sample. Bitumen used in pavement mixes should not indicate more than 1% loss in weight, but for bitumen having penetration values 150-200 up to 2% loss in weight is allowed.

Table 23:1: Tests for Bitumen with IS codes

Type of test	Test Method
Penetration Test	IS: 1203-1978
Ductility test	IS: 1208-1978
Softening Point test	IS: 1205-1978
Specific gravity test	IS: 1202-1978
Viscosity test	IS: 1206-1978
Flash and Fire Point test	IS: 1209-1978
Float Test	IS: 1210-1978
Determination of water content	IS: 1211-1978
Determination of Loss on heating	IS:1212-1978

